

DEPARTMENT OF THE ARMY TECHNICAL MANUAL

**ORGANIZATIONAL MAINTENANCE REPAIR PARTS
AND SPECIAL TOOLS LIST**

**SPRAYER, HERBICIDE, HELICOPTER MOUNTED
(AGRICULTURAL AVIATION ENG. CO., MODEL 3090-3)**

**FSN 3740-131 4599 SPRAYER PESTICIDE,
HELICOPTER MOUNTED (AGRICULTURAL AVIATION
ENG. CO., MODEL 3090) FSN 3740-999-2405**

THIS PUBLICATION IS A COURTESY QUICK COPY FROM THE UNITED STATES ARMY PUBLICATIONS DISTRIBUTION CENTER, ST. LOUIS, MISSOURI, TO MEET YOUR NEEDS WHILE WE REPLENISH OUR REGULAR STOCK.



HEADQUARTERS, DEPARTMENT OF THE ARMY

5 JANUARY 1970

Change in Force: C 1

**TM 5-3740-210-20P
C1**

Change }
No.1 }

**HEADQUARTERS
DEPARTMENT OF THE ARMY
WASHINGTON, D. C., 1 June 1971**

**Organizational Maintenance Repair Parts
and Special Tools List**

**SPRAYER, HERBICIDE, HELICOPTER MOUNTED
(AGRICULTURAL AVIATION ENG. CO. MODEL 3090-3)**

FSN 3740-131-4599

**SPRAYER, PESTICIDE, HELICOPTER MOUNTED
(AGRICULTURAL AVIATION ENG. CO. MODEL 3090)**

FSN 3740-999-2405

Current as of 19 April 1971

TNI 5-3740-210-20P, 5 January 1970, is changed as follows:

Where deletions, additions, and/or changes are made to manufacturers' code, FSN and/or page to the manual, appropriate changes should be made to the index.

SECTION II. PRESCRIBED LOAD ALLOWANCE

Page	Line	Action	(1) Federal Stock No.	(2) Description Ref No. Usable on & Mfr. Code Code		(3) 15-Day Org. Maint. Alw.			
						(A) 1-5	(B) 6.2 0	(C) 21-50	(D) 51-100
				Group 01 -Ground Loading System					
vii ix	7	Ch col. 1 and col. 2.	2920-294-3788	PLUG, SPARK XEJ6J (11583)		2	2	4	8
	10	Ch col. 1 and col. 2	3740-479-8777	Group 02-Boom Spray System BLADE, WINDMILL 6649-3 (22065)		*	2	2	2
	24A	Add entry to PLA in numerical order by FSN.	3740-248-4345	NOZZLE ASSEMBLY A 4664ALEF (82247)			2	3	6
	28A	Add entry to PLA in numerical order by FSN.	4730-401-3742	ORIFICE, DISC A D6 (82247)		*	2	3	6
	28B	Add entry to PLA in numerical order by FSN.	4730-401-3743	ORIFICE, DISC A D8 (82247)		*	2	3	6
	28C	Add entry to PLA in numerical order by FSN.	4730-401-3747	ORIFICE, DISC A D10 (82247)		*	2	3	6
	28D	Add entry to PLA in numerical order by FSN.	4730-401-3815	CORE: Nozzle A 56 (82247)		*	2	3	6
	28E	Add entry to PLA in numerical order by FSN.	4730-459-6521	CORE: Nozzle A 45 (82247)		*	2	3	6

Page	Line	Action	(1) Source maint. and recoverability code			(2) Federal Stock No.	(3) Description	(4) Unit of issue	(5) Qty incorporated in unit pack	(6) Qty incorporated in unit	(7) 15-Day Organizational maint. allowances				(8) Illustrations	
			S	M	R						1-5	6-20	21-50	51-100	Figure No.	Item or symbol No.

							Group 01-Ground Loading System									
6	8	Ch col. 1 and add FSN to col. 2.	P	O		5330-852-5034	SEAL: Crankcase housing 58688A (29201)									
	9	Ch col. 1 and add FSN to col. 2.	P	O		3130-179-7258	BEARING: Crankcase housing 58956 (29201)									
7	3	Ch col. 2.	P	O		2920-294-3788	PLUG, SPARK XEJ6J (11563) Group 02-Boom Spray System									
18	1	Ch col(s). 2 and 3.	P	O		3740-479-8777	BLADE, WINDMILL 6649-3 (22065)									
19	5	Add FSN to col. 2.	P	O		3740-248-4345	NOZZLE ASSEMBLY 466ALEF (82247).									
	7	Add FSN to col. 2.	P	O		4730-401-3815	ORIFICE, DISC D6 (82247)									
	8	Add FSN to col. 2.	P	O		4730-401-3742	ORIFICE, DISC D8 (82247)									
	9	Add FSN to col. 2.	P	O		4730-459-6521	ORIFICE, DISC D10 (82247)									
19	10	Add FSN to col. 2.	P	O		4730-401-3747	CORE: Nozzle 56 (82247)									
	11	Add FSN to col. 2.	P	O		4730-401-3742	CORE: Nozzle 45 (82247)									
	15	Ch col. 3.	P	O			CAP SUB-ASSEMBLY, END 9758ALEF (82247)									

By Order of the Secretary of the Army:

Official:

VERNE L. BOWERS,
Major General, United States Army,
The Adjutant General.

W. C. WESTMORELAND,
General, United States Army,
Chief of Staff.

Distribution:

To be distributed in accordance with DA Form 12-25, Sec I (qty rqr Block # 150), Organizational maintenance requirements for Mobility Support Equipment: Pest Control.

*U.S. GOVERNMENT PRINTING OFFICE: 1971-431131/2201.

TECHNICAL MANUAL }
 No. 5-3740-210-20P }

HEADQUARTERS
 DEPARTMENT OF THE ARMY
 WASHINGTON, D.C., 5 January 1970

ORGANIZATIONAL MAINTENANCE REPAIR PARTS AND SPECIAL

TOOLS LISTS

**SPRAYER, HERBICIDE, HELICOPTER MOUNTED (AGRICULTURAL
 AVIATION ENG. CO., MODEL 3090-3) FSN 3740-131-4599**

**SPRAYER, PESTICIDE, HELICOPTER MOUNTED (AGRICULTURAL
 AVIATION ENG. CO., MODEL 3090) FSN 3740-999-2405**

CURRENT AS OF 18 SEPTEMBER, 1969

		Listing Page	Illus Figure
SECTION	I. INTRODUCTION		
	II. PRESCRIBED LOAD ALLOWANCE		
	III. REPAIR PARTS FOR ORGANIZATIONAL MAINTENANCE		
Group	01 Ground Loading System	1	
	Ground Loading Hoses, Lines and Fittings.....		1
	Pump Exploded		2
	Engine Starting Components		3
	Engine and Gas Tank Exploded		4
	Carburetor, Governor and Related Parts		5
	Boom Spray System	8	
Group	02 Boom Spray System and Related Parts		6
	Frame Assembly and Related Parts		7
	Spray Tank and Related Parts		8
	Spray Tank Components		9
	Manual Control System		10
	Valve Assembly Exploded		11
	Windmill Assembly Exploded		12
	Pump and Brake Assembly		13
	Pump Exploded		14
	Nozzle Exploded		15
	Nozzle Exploded		16
SECTION	IV. SPECIAL TOOLS, TEST AND SUPPORT EQUIPMENT (not Applicable)		
	V. FEDERAL STOCK NUMBER AND REFERENCE NUMBER INDEX		

SECTION I.

INTRODUCTION

1. Scope

This manual lists repair parts, special tools, test and support equipment required for the performance of organizational maintenance of the sprayer.

2. General

This Repair Parts and Special Tools List is divided into the following sections:

a. Prescribed Load Allowance (PLA)-section II. A composite listing of the repair parts, special tools, test and support equipment having quantitative allowances for initial stockage at the organizational level.

b. Repair Parts--Section III. A list of repair parts authorized for the performance of maintenance at the organizational level in figure and item number sequence.

c. Special Tools, Test and Support Equipment - Section IV. A list of special tools, test and support equipment authorized for the performance of maintenance at the organizational level. (Not Applicable).

d. Federal Stock Number and Reference Number Index-Section V. A list of Federal Stock Numbers in ascending numerical sequence followed by a list of reference numbers in ascending alpha-numeric sequence, cross-referenced to the illustration figure number and item number.

NOTE

Items not illustrated are cross-referenced to group number.

3. Explanation of Columns

The following provides an explanation of columns in the tabular lists in sections II, III, and IV:

a. Source, Maintenance, and Recoverability Codes (SMR).

NOTE

Common hardware items known to be readily available in Army Supply channels are assigned Maintenance codes only. Source codes, Recoverability codes, and Maintenance Allowances are not assigned this category.

(1) Source code indicates the selection status and source for the listed item. Source codes are:

<i>Code</i>	<i>Explanation</i>
P	Repair parts which are stocked in or supplied from the GSA/DSA, or Army supply system and authorized for use at indicated maintenance categories
M	Repair parts which are not procured or stocked, but are to be manufactured in indicated maintenance levels
A	Assemblies which are not procured or stocked as such, but are made up of two or more units. Such component units carry individual stock numbers and descriptions are procured and stocked separately and can be assembled to form the required assembly at indicated maintenance categories.
X	Parts and assemblies which are not procured or stocked and the mortality of which normally is below that of the end item or component. The failure of such part or assembly should result in retirement of the end item from the supply system.
X1	Repair parts which are not procured or stocked. The requirement for such items will be filled by use of the next higher assembly or component.
X2	Repair parts which are not stocked. The indicated maintenance category requiring such repair parts will attempt to obtain same through cannibalization. Where such repair parts are not obtainable through cannibalization, requirements will be requisitioned, with accompanying justification through normal supply channels.
G	Major assemblies that are procured with PEMA funds for initial issue only as exchange assemblies of DSU and GSU level. These assemblies will not be stocked above DS and GS level or returned to depot supply level.

(2) Maintenance code indicates the lowest category of maintenance authorized to install the listed item. The maintenance level code is:

<i>Code</i>	<i>Explanation</i>
0	Organizational Maintenance

(3) Recoverability code indicates whether unserviceable items should be returned for recovery or salvage. Items not coded are expendable. Recoverability codes are:

<i>Code</i>	<i>Explanation</i>
R	Applied to repair parts (assemblies and components) which are considered economically repairable at direct and general support maintenance levels. When the maintenance capability to repair these items does not exist, they are normally disposed of at the

Code	Explanation
	GS level. When supply considerations dictate, some of these repair parts may be listed for automatic return to supply for depot level repair as set forth in AR 710-50. When so listed, they will be replaced by supply on an exchange basis.
S	Repair parts and assemblies which re economically repairable at DSU and GSU activities and which normally furnished by supply on an exchange basis. When items are determined by a GSU to be uneconomically repairable, they will be evacuated to a depot for evaluation and analysis before final disposition.
T	High dollar value recoverable repair parts which are subject to special handling and are issued on an exchange basis. Such repair parts normally are repaired or overhauled at depot maintenance activities
U	Repair parts specifically selected for salvage by reclamation units because of precious metal content, critical materials, or high dollar value reusable casings or castings.

b. *Federal Stock Number.* This column indicates the Federal stock number assigned to the item and will be used for requisitioning purposes.

c. *Description.* This column indicates the Federal item name and any additional description of the item required. Assembly components and subassemblies are indented under major assemblies. A part number or other reference number is followed by the applicable five-digit Federal supply code for manufacturers in parenthesis. Repair parts quantities included in kits and sets are shown in front of the repair part name. Material required for manufacture or fabrication is identified.

d. *Unit of Measure (U/M).* 3 2-character alphabetic abbreviation indicating the amount or quantity of the item upon which the allowances are based, e.g., ft, ea, pr, etc.

e. *Quantity Incorporated in Unit.* This column indicates the quantity of the item used in the assembly group. A "V" appearing in this column in lieu of a quantity indicates that a definite quantity cannot be indicated (e.g., shims, spacers, etc.).

f. *Fifteen-Day Organizational Maintenance Allowance.*

(1) The allowance columns are divided into four subcolumns. Indicated in each subcolumn opposite the first appearance of each item is the total quantity of

items authorized for the number of equipments supported. Subsequent appearances of the same item will have the letters "REF" in the allowance column. To locate the referenced item, locate the FSN or reference number in the index. The earliest figure and item number is the referenced item. Items authorized for use as required but not for initial stockage are identified with an asterisk in the allowance column.

(2) The quantitative allowance for organizational level of maintenance represents one initial prescribed load for a 15-day period for the number of equipments supported. Units authorized additional prescribed loads, multiply the number of prescribed loads by the quantity in the appropriate density column to determine the number of repair parts authorized.

(3) To determine allowances when supporting more than 100 of these equipments. First, divide the number of equipments supported by 100 by moving the decimal two spaces left; second, multiply the result by the quantity in the 51-100 equipment is 40; for 150 equipments, multiply 40 by 1.50 or 60 parts authorized.

(4) Subsequent changes to allowances will be limited as follows: No change in the range of items is authorized. If additional items are considered necessary, recommendation should be forwarded to U.S. Army Mobility Equipment Command for exception or revision to the allowance list. Revisions to the range of items authorized will be made by the U.S. Army Mobility Equipment Command based upon engineering experience, demand data, or TAERS information.

g. *Illustration.* This column is divided as follows:

(1) *Figure number.* Indicates the figure number of the illustration in which the item is shown.

(2) *Item number.* Indicates the callout number used to reference the item in the illustration.

4. Special Information

a. Identifications of the usable on codes included in the description columns of this publication are: (Applicable only when identifying parts to particular serial number range or model).

Code	Used on
Uncoded items	All models
A	Model 3090
B	Model 3090-3

b. Repair parts mortality has been based on 600 hours of operation per year.

c. Parts which require manufacture or assembly at a category higher than that authorized for installation will indicate in the source column the higher category.

d. The following publication pertains to the sprayer and its components.

TM 5-3740-210-12 Operator, Organizational Maintenance Manual.

5. How to Locate Repair Parts

a. When Federal stock number or reference number is unknown:

(1) *First.* Using the table of contents, determine the assembly group within which the repair part belongs. This is necessary since illustrations are prepared for assembly groups and listings are divided into the same groups.

(2) *Second.* Find the illustration covering the assembly group to which the repair part belongs.

(3) *Third.* Identify the repair part on the illustration and note the illustration figure and item number of the repair part.

(4) *Fourth.* Using the Repair Part Listing, find the assembly to which the repair part belongs and locate the illustration figure and item number note on the illustration.

b. When the Federal stock number or reference number is known:

(1) *First.* Using the Index of Federal Stock Numbers and Reference Numbers find the pertinent Federal stock number or reference number. This index is in ascending FSN sequence followed by a list of reference numbers in alpha-numeric sequence, cross referenced to the illustration figure number and item number.

(2) *Second.* Using the Repair Part Listing, find the assembly group of the repair part and illustration figure number and item number referenced in the Index of Federal Stock Numbers and Reference Numbers.

c. When the Federal stock number or reference number is known and the repair part is not illustrated.

(1) *First.* Using the Index of Federal Stock Numbers and Reference Numbers find the pertinent Federal stock number or reference number in the section titled items not Illustrated and note the group number This section of the Index is in ascending FSN sequence followed by a list of reference numbers in alpha-numeric sequence, cross-referenced to assembly group number.

(2) *Second.* Using the Table of Contents, locate the assembly group number and page number.

(3) *Third.* Using the applicable group number and page number locate the pertinent stock number or reference number in the Repair Parts Listing. Items

which are not illustrated are listed at the end of the assembly group to which they belong.

6. Abbreviations

Assy.....	Assembly
Deg	Degree
Ea	Each
In	Inch (s)
Lg	Long, Length
Lh	Left hand
Mtg	Mounting
No.....	Number
NPT	National Pipe Threads
Rh	Right hand
Thd	Thread(s)
Thk	Thick (ness)
U/O	Used on

7. Federal Supply Codes for Manufacturers

Code	Manufacture
02615.....	Nylock Co., the Div. of United Shoe Machinery Corp.
17224.....	Russell Burdsall and Ward Bolt and Nut Co.
22065.....	Agricultural Aviation Engineering Co.
29201.....	Textron, Inc. Homelite Div.
29337.....	Hoover Ball Div. of Hoover Ball and Bearing Co. Erwin Plant.
72100	Marshall town Mfg., Inc. Dial Thermometer Div.
73184.....	Heim Universal Corp., The
77988	Mobil Chemical Co. Chemical Coatings Div.
78357.....	Snap-Tite, Inc.
79136.....	Waldes Kohinoor, Inc.
81350	Joint Army-Navy Specifications
82247	Spraying Systems Co., Inc.
88044.....	Aeronautical Standards
95957	Brown-line Corp.
96906	Military Standards
98991	Worcester Valve Co., Inc.
99189	Crane Packing Co. Lapmaster Div.

8. Recommendations for Maintenance Publication Improvements

Report of errors, omissions, and recommendations for improving this publication by the individual user is encouraged. Reports should be submitted on DA Form 2028 (Recommended Changes to Publications) and forwarded direct to Commanding General, U.S. Army Mobility Equipment Command, ATTN: AMSME-MPP, 4300 Goodfellow Boulevard, St. Louis, Mo. 63120.

**SECTION II
PRESCRIBED LOAD ALLOWANCE**

(1) Federal stock number	(2) Description usable on code	(3) 15-Day org maint. alw			
		(A) 1-5	(B) 6-20	(C) 21-50	(D) 51-100
2805-981-8749	Group 01-Ground Loading System GASKET: Bearing housing to crankcase mtg 63355 (29201)		2	2	2
2910-177-7766	LINE, FUEL: Flexible, tank to carburetor 59644-1 (29201)				2
2910-177-7767	CAP, FUEL TANK A64140-1 (29201)		2	2	2
2910-177-7768	CARBURETOR A59535B (29201)				2
2920-177-7769	ROTOR, MAGNETO 58809 (29201)		2	2	2
2920-177-7770	CONDENSER 63250 (29201)			2	2
2920-177-7771	PLUG, SPARK 54576S (29201)	2	2	4	8
2920-977-1118	LEAD, ELECTRICAL, HIGH TENSION 54408 (29201)			2	2
2920-979-6475	POINT SET, IGNITION A58914 (29201)			2	2
2940-982-9397	ELEMENT, AIR FILTER 63589 (29201)	2	2	4	8
2990-177-7772	PULLEY, STARTER A64446 (29201)			2	2
2990-177-7773	PAWL: starter 58756 (29201)			2	2
2990-978-7302	ROPE, STARTER 58806 (29201)	2	2	4	8
2990-977-1004	GRIP, ROPE: starter 58915 (29201)	2	2	4	8
3130-179-7258	BEARING, NEEDLE: bearing housing 58956 (29201)		2	2	2
3740-179-6722	HOSE, RUBBER 3085-5 (22065)				2
4320-168-2093	IMPELLER: pump 58718-2 (29201)				2
4320-168-2095	SLINGER 62692 (29201)		2	2	2
4320-168-2096	CAP: drain and filler, pump 59594A (29201)			2	2
4320-168-2097	PUMP AND ENGINE ASSEMBLY XLS 1-1-2x3 (29201)				2
4320-168-2098	PLATE WEAR: impeller 62693 (29201)				2
4730-168-2088	VALVED NIPPLE AVHN24-24FADCH24 (78357)			2	2
4730-168-2084	VALVED COUPLER AVHC24-24FAMPH24V (78357)				2
4730-168-2088	STRAINER ASSEMBLY 4164P30 (22065)				2
4730-168-2089	SEAL: valved coupler H24-56V (78357)		2	2	4
4730-168-2090	VALVED COUPLER AVHC24-24MAMPH24V (78357)				2
4820-168-2065	KIT, REPAIR, VALVE K4211T (98991)		2	2	2

(1) Federal stock number	(2) Description usable on code	(3) 15-Day org maint. alw			
		(A) 1-5	(B) 6-20	(C) 21-50	(D) 51-100
4820-724-0768	VALVE 1124211T (98991)				2
5310-797-4065	WASHER, SEALING: bearing housing to impeller housing mtg 62717 (29201)		2	2	4
5330-054-6865	PACKING, PREFORMED AN6230-7 (88044)		2	2	4
5330-179-6243	GASKET: impeller housing to pump housing mtg 54183 (29201)			2	2
5330-179-6244	GASKET: wear plate 54182 (29201)				2
5330-179-6247	GASKET: drain and filler cap 59910 (29201)		2	2	2
5330-179-6249	SEAL ASSEMBLY: impeller mtg A54575 (29201)		2	2	2
5330-852-5034	SEAL: bearing housing 58688A (29201)		2	2	2
5335-178-1368	SCREEN, STRAINER: 30 mesh 4163-30 (22065)		2	2	2
5340-178-4366	MOUNT, VIBRATION: engine and pump mtg 54861 (29201)		2	2	2
5340-178-1366	SHIM: impeller mtg, 0.015 IN. thk. 62696 (29201)		2	2	4
5340-178-1367	SHIM: impeller mtg, 0.010 IN. thk. 62696 (29201)		2	2	4
5340-178-1368	SPRING, RECOIL: starter 58764A (29201)			2	2
5340-987-5858	SPRING: starter pawl 58758 (29201)				2
	Group 02-Boom Spray System				
1670-179-6260	FITTING, TIE DOWN: tank mtg 2770-3 (22065)				2
1670-179-6251	STRAP ASSEMBLY WB661-1-52N (95957)			2	2
1670-179-6252	STRAP ASSEMBLY WB661-1-25N (95957)			2	2
3130-179-7259	BEARING 99208 (29337)		2	2	2
3740-179-6675	PLATE, BACK 6654-2 (22065)				2
3740-179-6676	SHOE, BRAKE 6654-3 (22065)			2	2
3740-179-6679	GASKET: filler 3064 (22065)				2
3740-179-6683	FORK, BRAKE 6011 (22065)			2	2
3740-179-6684	LINK, BRAKE 3049 (22065)			2	2
3740-179-6683	FORK: valve end 3091-17 (22065)				2
3740-179-6690	FORK: control end 3091-19 (22065)				2
3740-179-6692	NOZZLE ASSEMBLY 8355 (82247)	B	2	4	7
3740-179-6693	CAP SUB ASSEMBLY, END 9758NYL (82247)	B	2	2	4
3740-179-6694	RETAINER 8476AL (82247)	B	2	2	4
3740-179-6695	TIP, NOZZLE 2510- (82247)	B	2	4	7
					14

(1) Federal stock number	(2) Description usable on code	(3) 15-Day org maint. alw			
		(A) 1-5	(B) 6-20	(C) 21-50	(D) 51-100
3740-179-6696	TIP, NOZZLE 2530- (82247) B	2	4	7	14
3740-179-6698	TIP, NOZZLE 2560 (82247) B	2	4	7	14
3740-179-6699	DIAPHRAGM, VITON 4620VI (82247) B	4	10	20	42
3740-179-6699	DIAPHRAGM, VITON 4620VI (82247) A	32	80	160	336
3740-179-6700	DIAPHRAGM, TEFLON 6227 (82247) A	32	80	160	886
3740-179-6703	FILLER 3063 (22065)				2
3740-179-6706	CAP, HUB 6648 (22065)				2
3740-179-6707	ACTUATOR 6652 (22065)			2	2
3740-179-6708	SCREW, ADJUSTING 6653 (22065)				2
3740-179-6709	BLADE, WINDMILL 6649 (22065)		2	2	2
3740-179-6711	GASKET: inlet mtg 6642 (22065)		2	2	2
3740-179-6715	GASKET: body to case mtg 6306 (22065)		2	2	4
3740-179-6721	KIT, REPAIR, VALVE K7400 (22065)			2	2
3740-179-6723	BOOM ASSEMBLY, OUTBOARD 3069-11 (22065)				2
3740-179-6726	RING, HALF 3032 (22065)				2
3740-179-6727	STRUT ASSEMBLY 3028 (22065)				2
3740-179-6728	ROD, END MD46-16 (73134)				2
3740-179-6729	CLAMP ASSEMBLY 3031 (22065)			2	2
3740-179-6730	BRACE ASSEMBLY 3029 (22065)			2	2
3740-179-6732	FORK 3029-1 (22065)		2	2	2
3740-179-6733	CABLE ASSEMBLY: center 3085-1 (22065)				2
3740-179-6735	CABLE ASSEMBLY: 2 ft 3085-7 (22065)				2
3740-179-6737	CAP: filler 2646-1 (22065)				2
3740-179-6739	STRAINER 3068 (22065)				2
4720-143-9264	HOSE ASSEMBLY: pressure gage MS28741-5-0720 (96906)				2
4730-168-2086	PLUG 8400-3-4 NPT (82247)			2	2
4730-168-2087	PLUG: nylon 1-4 NPT (17224)			2	2
4730-186-7798	NIPPLE: brass AN911-2 (81350)	2	2	4	8
5306-156-2338	BOLT, MACHINE AN4C6A (88044)			2	2
5306-795-3280	BOLT, MACHINE LP3-22A (02615)		2	2	4

(1) Federal stock number	(2) Description usable on code	(3) 15-Day org maint. alw			
		(A) 1-5	(B) 6-20	(C) 21-50	(D) 51-100
5310-531-9515	WASHER, LOCK AN960C416 (88044)			2	2
5310-797-3615	NUT, ACORN 6672 (22065)		2	2	4
5330-179-6246	GASKET: valve mtg 7407 (22065)				2
5330-179-6248	SEAL ASSEMBLY: teflon 6308T (99189)			2	2
5340-143-0335	RING, Snap 5160-66 (22065)		2	2	4
5340-178-1369	SPRING, BRAKE SHOE 6654-4 (22065)			2	2
5340-622-1799	RETAINER, BRAKE SHOE 5133-37 (22065)		2	2	2
5340-804-9746	RING, SNAP: bearing retaining N5000-156 (79136)		2	2	4
	NOZZLE ASSEMBLY 4664ALEF (82247)	A	2	3	6
	ORIFICE, DISC D6 (82247)	A	2	3	6
	ORIFICE, DISC D8 (82247)	A	2	3	6
	ORIFICE, DISC D10 (82247)	A	2	3	6
	CORE: nozzle 56 (82247)	A	2	3	6
	CORE: nozzle 45 (82247)	A	2	3	6
	CAP SUB-ASSEMBLY, END 9758ASB (82247)	A	2	3	6
	RETAINER 4624AL (82247)	A	2	3	6

(1) SMR CODE	(2) FEDERAL STOCK NUMBER	(3) DESCRIPTION REF NUMBER & MFR CODE	(4) USABLE ON CODE	(5) UNIT MEAS QTY INC IN UNIT	(6) 15-DAY ORGANIZATIONAL MAINTENANCE ALW				(7) ILLUS- TRATION		
					(a)	(b)	(c)	(d)	(a)	(b)	
					1-5	6-20	21-50	51-100	FIG NO.	ITEM NO.	
		SECTION III - REPAIR PARTS FOR ORGANIZATIONAL MAINTENANCE									
		GROUP 01 - GROUND LOADING SYSTEM									
X20		LOADING SYSTEM, LIQUID 3080 (22065)		EA	1						
X20		HOSE ASSELY 3083-1 (22065)		EA	2				1	1	
P 0	4730-168-2089	SEAL: valve coupler H24-56v (78357)		EA	4	*	2	2	4	1	2
P 0	4730-168-2084	VALVED COUPLER AVHC24-2FAMPH24V (78357)		EA	1	*	*	*	2	1	3
P 0	4730-168-2083	VALVED NIPPLE AVHN24-24FADCH2 (78357)		EA	1	*		2	2	1	4
P 0	3740-179-6722	HOSE, ASSEMBLY 3083-5 (22065)		EA	1	*	*	*	2	1	5
X20		HOSE ASSEMBLY 3083-3 (22065)		EA	1					1	6
X20		PIPE 3083-13(22065)		EA	1					1	7
0	4730-27-4231	ELBOW, PIPE: 1 1/2 IN. NPT, 90 DEG 3083-11 (22065)		EA	1					1	8
P 0	4730-168-2083	VALVED NIPPLE AVHN24-24FADCH24 (78357)		EA	1	REF	REF	REF	REF	1	REF
P 0	3740-179-6722	HOSE, RUBBER 3083-5 (22065)		EA	1	REF	REF	REF	REF	1	REF
P 0	4730-168.2090	VALVED. COUPLER AVHC24-24MAMPH24V (78357)		EA	2	*	*	*	2	1	9
P 0	4820-724-0768	VALVE 1124211T (98991)		EA	1	*	*	*	2	1	10
P 0	4730-168-2088	STRAINER ASSEMBLY 4164P30 (22065)		EA	1	*	*	*	2	1	11
X1		BODY STRAINER 4165P (22065)		EA	1					1	12
X1		CAP ASSEMBLY, STRAINER 4166 (22065)		EA	1					1	13
P 0	5335-178-1363	SCREEN, STRAINER: 30 MESH 4163-30 (22065)		EA	1	*	2	2	2	1	1
P 0	5330-054-6865	PACKING, PREFORMED AN6230-7 (88044)		EA	1	*	2	2	4	1	15
P 0 R	4320-168-2097	PUMP AND ENGINE ASSEMBLY XLS1-1-2X3 (29201)		EA	1	*	*	*	2	1	16
X20		SCREW, CAP, HEXAGON HEAD: ENGINE LEGS MTG TO FAN HOUSING, No. 12-24 THD SIZE 1-11/16 IN. LG 58963 (29201)		EA	2					2	1
X20		LEG: ENGINE MTG. LH 59196-2 (29201)		EA	1					2	2
X20		SCREW, CAP, HEXAGON HEAD: ENGINE LH LEG MTG TO FUEL TANK, NO. 12-24 THD SIZE 1/2 IN. LG 80821 (29201)		EA	1					2	3

(1) SMR CODE	(2) FEDERAL STOCK NUMBER	(3) DESCRIPTION REF NUMBER & MFR CODE	(4) USABLE ON CODE	(5) UNIT MEAS QTY INC IN UNIT	(6) 15-DAY ORGANIZATIONAL MAINTENANCE ALW				(7) ILLUS- TRATION		
					(a)	(b)	(c)	(d)	(a)	(b)	
					1-5	6-20	21-50	51-100	FIG NO.	ITEM NO.	
0	5305-682-6023	SCREW, CAP, HEXAGON HEAD: ENGINE RN LEG MTG TO CARBURETOR CHAMBER No. 12-24 To SIZE, 7/8 IN. LG 80891-(29201)		EA	1					2	4
X20		LEG: ENGINE MTG, RH 59195-2 (29201)		EA	1					2	5
P 0	2805-981-8749	GASKET: BEARING HOUSING TO CRANKCASE MTG 63355 (29201)		EA	1	*	2	2	2	2	6
X20		HOUSING, BEARING: PUMP A59547 (29201)		EA	1					2	7
P 0	3130-179-7258	BEARING, NEEDLE: BEARING HOUSING 58956 (29201)		EA	1	*	2	2	2	2	8
P 0	5330-852-5034	SEAL: BEARING HOUSING 58688A (2901)		EA	1	1	2	2	2	2	9
X20		SCREW, CAP, HEXAGON HEAD: BEARING HOUSING TO CRANKCASE MTG, No. 12-24 TND SIZE 9/16 IN. LG 80899 (29201)		EA	5					2	10
P 0	4320-168-2095	SLINGER 62692 (29201)		EA	1	*	2	2	2	2	11
P 0	4320-168-2094	HOUSING IMPELLER 58661-2 (29201)		EA	1	1	*	*	*	2	12
P 0	5310-797-4065	WASHER, NONMETALLIC: BEARING HOUSING TO IMPELLER HOUSING MTG 62717 (29201)		EA	4	*	2	2	4	2	13
0	5305-818-7814	SCREW, MACHINE: BEARING HOUSING TO IMPELLER HOUSING MTG, No. 12-24 THD SIZE, 3/4 IN LG 80916 (29201)		EA	4					2	14
P 0	5340-178-1367	SHIM: IMPELLER MTG, 0.010 IN. THK 62695 (29201)		EA	2	*	2	2	4	2	15
P 0	5340-178-1366	SHIM: IMPELLER MTG, 0.015 IN. THK 62696 (29201)		EA	2	*	2	2	2	4	15
P 0	5330-179-6249	SEAL ASSEMBLY: IMPELLER MTG A54575 (29201)		EA	1	*	2	2	2	2	16
P 0	4320-168-2093	IMPELLER: PUMP 58718-2 (29201)		E	1	*	*	*	2	2	17
P 0	5330-179-6243	GASKET: IMPELLER HOUSING TO PUMP HOUSING MTG 54183 (29201)		EA	2	*	*	2	2	2	18
P 0	4320-168-2098	PLATE, WEAR: IMPELLER 62693-2 (29201)		EA	1	*	*	*	2	2	19
X20		MUFFLER, EXHAUST 59550-1 (29201)		EA	1					2	20
X20		CLAMP, LOOP: MUFFLER MTG 59549-1(29201)		EA	1					2	21
X20		BRACKET: MUFFLER MTG 62691-1 (29201)		EA	1					2	22
P 0	5310-543-2740	WASHER, LOCK: MUFFLER BRACKET MTG, 1/4 IN. SCREW SIZE, INTERNAL, EXTERNAL TOOTH 83077-1 (29201)		EA	2					2	23
P 0	5305-021-3615	SCREC, CAP, HEXAGON HEAD: MUFFLER BRACKET MTG, 1/4-20 THD SIZE, 1/2 IN. LG 80355 (29201)		EA	2					2	24
P 0	5330-179-6244	GASKET: WEAR PLATE 54182 (29201)		EA	1	*	*	*	2	2	25

(1) SMR CODE	(2) FEDERAL STOCK NUMBER	(3) DESCRIPTION REF NUMBER & MFR CODE	(4) USABLE ON CODE	(5) UNIT MEAS QTY INC IN UNIT	(6) 15-DAY ORGANIZATIONAL MAINTENANCE ALW				(7) ILLUS- TRATION		
					(a)	(b)	(c)	(d)	(a)	(b)	
					1-5	6-20	21-50	51-100	FIG NO.	ITEM NO.	
0		SCREW, CAP, HEXAGON HEAD: IMPELLER HOUSING TO PUMP HOUSING MTG, 1/4-20 THD SIZE, 1/2 IN. LG 80882 (29201)		EA	4					2	26
P 0	4320-168-2096	CAP: DRAIN AND FILLER CAP 59594A (29201)		EA	2	*	*	2	2	2	27
P 0	5330-179-6247	GSKET: DRAIN AND FILLER CAP 59910 (29201)		EA	2	*	2	2	2	2	28
X20		HOUSING, PUMP 58619-2 (29201)		EA	1					2	29
X20		NIPPLE, PIPE: JUMP INLET 54185-1 (29201)		EA	1					2	30
X20		BASE: PUMP MTG 54867-1 (29201)		EA	1					2	31
P 0	5340-178-1365	MOUNT, MIGRATION: ENGINE AND PUMP MTG 54861 (29201)		EA	4	*	2	2	2	2	32
X20		WASHER: SNUBBING, MIGRATION MOUNT MTG 54862 (29201)		EA	8					2	33
0	5305-021-3665	SCREW, MACHINE: ENGINE MTG, 1/4-20 THD SIZE, 1-1/4 IN. LG 80259 (29201)		EA	2					2	34
0	5305-207-8253	SCREW, MACHINE: PUMP MTG 1/4-20 THD SIZE, 1 IN. LG 80271 (29201)		EA	2					2	35
0	5310-933-8121	WASHER, LOCK: ENGINE AND PUMP MTG, 1/4 IN. SCREW SIZE 83009 (29201)		EA	4					2	36
0	5310-815-9849	NUT, PLAIN, HEXAGON: ENGINE MTG, 1/4-20 THD SIZE 81053 (29201)		EA	2					2	37
X20		SCREW, MACHINE: VIBRATION MOUNT MTG, No. 10 SCREW SIZE 80042 (29201)		EA	16					2	38
X20		WASHER, LOCK: VIBRATION MOUNT MTG, NO. 10 SCREW SIZE 83046 (29201)		EA	16					2	39
X20		NUT, PLAIN HEXAGON: VIBRATION MOUNT MTG, No. 10 THD SIZE 81010-1 (29201)		EA	16					2	40
X20		LEAD, ELECTRICAL: GROUND A59031 (29201)		EA	1					3	1
X20		SWITCH, TOGGLE: IGNITION A57650-3 (29201)		EA	1					3	2
X20		PLATE: TOGGLE SWITCH MTG 72085 (29201)		EA	1					3	3
0	5305-510-1476	SCREW, CAP, HEXAGON HEAD: ENGINE FAN HOUSING MTG, No. 12-24 THD SIZE 5/8 1N. LG 80676 (29201)		EA	4					3	4
0		SCREW, CAP, HEXAGON. HEAD: ENGINE FAN HOUSING MTG, No. 12-24 THD SIZE, 1-11/16 IN. LG 58963 (29201)		EA	3					3	5
X20		HOUSING, FAN: ENGINE A64516 (29201)		EA	1					3	6
X1		BUSHING, SLEEVE: STARTER POST 64443 (29201)		EA	1					3	7
X1		BUSHING, SLEEVE: STARTER ROPE 59313 (29201)		EA	1					3	8

(1) SMR CODE	(2) FEDERAL STOCK NUMBER	(3) DESCRIPTION REF NUMBER & MFR CODE	(4) USABLE ON CODE	(5) UNIT MEAS QTY INC IN UNIT	(6) 15-DAY ORGANIZATIONAL MAINTENANCE ALW				(7) ILLUS- TRATION		
					(a)	(b)	(c)	(d)	(a)	(b)	
					1-5	6-20	21-50	51-100	FIG NO.	ITEM NO.	
P 0	2990-978-7302	ROPE, STARTER 58806 (29201)		EA	1	2	2	4	8	3	9
P 0	2990-977-1004	GRIP, ROPE: STARTER 58915 (29201)		EA	1	2	2	4	8	3	10
X20		INSERT: STARTER ROPE GRIP. 58847 (29201)		EA	1					3	11
P 0	5340-178-1368	SPRING, RECOIL: STARTER 58764A (29201)		EA	1	*	*	2	2	3	12
P 0	2990-177-7772	PULLEY, STARTER A64446 (29201)		EA	1	*	*	2	2	3	13
X1		BUSHING: STARTER PULLEY 64400 (29201)		EA	1					3	14
X1		LOCK: STARTER SPRING 64049A (29201)		EA	1					3	15
X20		WASHER, RETAINING: PULLEY MTG 58763 (29201)		EA	1					3	16
0	5305-043-1942	SCREW, CAP, HEXAGON HEAD: PULLEY MTG, No. 10-32 THD SIZE, 1/2 IN. LG 80648 (29201)		EA	1					3	17
0	5310-660-2648	NUT, PLAIN, HEXAGON: MAGNETO ROTOR MTG. TO CRANKSHAFT, 5/16-24 THD SIZE 81117 (29201)		EA	1					3	18
0	5310-543-4431	WASHER, LOCK: MAGNETO ROTOR. MTG TO CRANKSHAFT, 5/16 IN. SCREW SIZE 83002 (29201)		EA	1					3	19
0	5310-625-5756	WASHER, FLAT: MAGNETO ROTOR MTG TO CRANKSHAFT, 5/16 IN. SCREW SIZE 84056 (29201)		EA	1					3	20
0	5310-059-9908	NUT, SELF-LOCKING, HEXAGON: STARTER SCREEN MTG TO PAWL STUD, No. 10-32 THD SIZE 81109-2 (29201)		EA	2					3	21
X20		STUD, SHOULDER: PAWL MTG 58757B (29201)		EA	2					3	22
P 0	2990-177-7773	PAWL: STARTER 58756 (29201)		EA	2	*	*	2	2	3	23
X20		WASHER, FLAT: PAWL -MTG 58851 (29201)		EA	2					3	24
P 0	5310-937-5358	SPRING: STARTER PAWL 58758 (29201)		EA	2	*	*	*	2	3	25
X20		SCREEN: STARTER 58765 (29201)		EA	1					3	26
P 0	2920-177-7769	ROTOR, MAGNETO 58809 (29201)		EA	1	*	2	2	2	3	27
P 0	2920-177-7770	CONDENSER 63250 (29201)		EA	1	*	2	2	2	3	28
X20		CLAMP: CONDENSER MTG 59622 (29201)		EA	1					3	29
X20		SCREW, ASSEMBLED WASHER: CONDENSER CLAMP MTG 30261 (29201)		EA	1					3	30
X20		COVER: BREAKER BOX 58811 (29201)		EA	1					3	31
X20		TERMINAL BLOCK ASSEMBLY A58934 (29201)		EA	1					3	32
P 0	2929-979-6475	POINT SET, IGNITION A58914 (29201)		EA	1	*	*	2	2	3	33

(1) SMR CODE	(2) FEDERAL STOCK NUMBER	(3) DESCRIPTION REF NUMBER & MFR CODE	(4) USABLE ON CODE	(5) UNIT MEAS QTY INC IN UNIT	(6) 15-DAY ORGANIZATIONAL MAINTENANCE ALW				(7) ILLUS- TRATION		
					(a)	(b)	(c)	(d)	(a)	(b)	
					1-5	6-20	21-50	51-100	FIG NO.	ITEM NO.	
X1		WASHER, FLAT: POINT SET 28028-(29201)		EA	2					3	34
X1		CLIP: POINT SET 28008 (29201)		EA	1					3	35
X20		SCREW ASSEMBLED WASHER: POINT SET MTG 76421 (29201)		EA	1					3	36
X20		GASKET: BREAKER BOX COVER MTG 58810 (29201)		EA	1					3	37
X20		SPRING: BREAKER BOX COVER 76413 (29201)		EA	1					3	36
X20		BOX, BREAKER 58875A (29201)		EA	1					3	39
X20		GASKET: IN BREAKER BOX 59538 (29201)		EA	1					3	40
X20		SEAL IN BREAKER BOX 59760 (29201)		EA	1					3	41
X20		COIL 58874 (29201)		EA	1					3	42
P 0	2920-977-1118	LEAD, ELECTRICAL: HIGH TENSION 54408 (29201)		EA	1	*	*	2	2	3	43
X20		SCREW, MACHINE: COIL CLIP AND COIL GROUND 58872 (29201)		EA	1					3	44
X20		CLIP: COIL MTG 63726 (29201)		EA	1					3	45
X20		COVER: FUEL TANK A63271 (29201)		EA	1					4	1
X20		CAP, SLOTTED: FUEL TANK COVER A56580-1 (29201)		EA	1					4	2
X20		GASKET: FUEL TANK COVER CAP 56607 (29201)		EA	1					4	3
X20		WASHER FELT: FUEL WICK STUD 59457 (29201)		EA	1					4	4
X20		PLUG, PIPE: FUEL TANK 59571 (29201)		EA	1					4	5
X20		TANK, FUEL 58732-4 (29201)		EA	1					4	6
X20		SCREW, SHOULDER: FUEL TANK MTG, 1/4-20 THD SIZE, 3/4 IN. LG 63407 (29201)		EA	3					4	7
P 0	2910-177-7767	CAP, FUEL TANK A64140-1 (29201)		EA	1	*	*	2	2	4	8
X1		GASKET: FUEL TANK CAP 65358 (29201)		EA	1					4	9
0	5310-059-9908	NUT, SELF-LOCKING, HEXAGON: FUEL WICK STUD, No. 10-32 THD SIZE 81109-2 (29201)		EA	1					4	10
0	5310-966-4117	WASHER, FLAT: FUEL WICK STUD, No. 10 SCREW SIZE 84003-1 (29201)		EA	1					4	11
X20		SPRING, HELICAL, COMPRESSION: FUEL WICK STUD 58867 (29201)		EA	1					4	12
X20		WASHER: FUEL WICK STUD 58866 (29201)		EA	1					4	13
X20		GASKET: FUEL WICK STUD 58865 (29201)		EA	1					4	14

(1) SMR CODE	(2) FEDERAL STOCK NUMBER	(3) DESCRIPTION REF NUMBER & MFR CODE	(4) USABLE ON CODE	(5) UNIT MEAS QTY INC IN UNIT	(6) 15-DAY ORGANIZATIONAL MAINTENANCE ALW				(7) ILLUS- TRATION		
					(a)	(b)	(c)	(d)	(a)	(b)	
					1-5	6-20	21-50	51-100	FIG NO.	ITEM NO.	
X20		WICK: FUEL PICK-UP, 58862 (29201)		EA	1					4	15
X20		STUD: FUEL PICK-UP WICK MTG 58519 (29201)		EA	1					4	16
X20		SCREW, MACHINE: FUEL TANK COVER MTG, No. 6 THD SIZE, 1/2 IN. LG 80513 (29201)		EA	16					4	17
P 0	2910-177-7766	LINE, FUEL FLEXIBLE 5964-1 (29201)		EA	1	*	*	*	2	4	18
X20		ELBOW FUEL LINE AT TANK 59642 (29201)		EA	1					4	19
X20		GASKET: CYLINDER MTG 58513 (29201)		EA	1					4	20
X20		HOUSING, CRANKCASE: ENGINE A58799D (29201)		EA	1					4	21
X20		SEAL: CRANKCASE HOUSING 58688A (29201)		EA	1					4	22
X20		BEARING: CRANKCASE HOUSING 58956 (29201)		EA	1					4	23
X20		STUD, PLAIN: CYLINDER HEAD -MTG 55871 (29201)		EA	4					4	24
X2		PIN, DOWEL: CRANKCASE, TO PUNP HOUSING MTG 63621 (29201)		EA	2					4	25
X20		RACE, BEARING: CRANKCASE 58725 (29201)		EA	2					4	26
X20		BEARING, NEEDLE: CRANKSHAFT 58726 (29201)		EA	2					4	27
X20		KEY, WOORUFF: MAGNETO ROTOR MTG TO CRANKSHAFT 75078 (29201)		EA	1					4	28
X2C		CRANISHAFT: ENGINE 63497-1 (29201)		EA	1					4	29
X20		ROD, CONNECTING A63477 (29201)		EA	1					4	30
X1		BEARING, SLEEVE: CONNECTING ROD 58724 (29201)		EA	1					4	31
X1		SCREW, CAP, SOCKET HEAD: CONNECTING ROD 80889 (29201)		EA	2					4	32
X20		ROLLER SET: CONNECTING ROD A63496 (29201)		EA	1					4	33
X20		PISTON AND PIN A58903B (29201)		EA	1					4	34
X1		RING, RETAINING: PISTON PIN 75120 (29201)		EA	1					4	35
X1		RING, RETAINING: PISTON PIN 64813 (29201)		EA	1					4	36
X20		RING, PISTON 58877 (29201)		EA	2					4	37
0	5305-360-7668	SCREW, CAP, HEXAGON HEAD: MANIFOLD MTG, No. 10-24 THD SIZE, 3/4 IN. LG 80867 (29201)		EA	2					4	38
0	5310-933-8121	WASHER, LOCK: CYLINDER MTG, 1/4 IN. SCREW SIZE 83009 (29201)		EA	4					4	39

(1) SMR CODE	(2) FEDERAL STOCK NUMBER	(3) DESCRIPTION REF NUMBER & MFR CODE	(4) USABLE ON CODE	(5) UNIT MEAS QTY INC IN UNIT	(6) 15-DAY ORGANIZATIONAL MAINTENANCE ALW				(7) ILLUS- TRATION		
					(a)	(b)	(c)	(d)	(a)	(b)	
					1-5	6-20	21-50	51-100	FIG NO.	ITEM NO.	
0	5310-655-6932	NUT, PLAIN, HEXAGON: CYLINER MTG, 1/4-28 THD SIZE 81065-2 (29201)		EA	4					4	40
X20		MANIFOLD: ENGINE 59548-2 (29201)		EA	1					4	41
P 0	2920-177-7771	PLUG, SPARK 54576 (29201)		EA	1	2	2	4	8	4	42
X1		GASKET: SPARK PLUG 25038 (29201)		EA	1					4	43
X20		CYLINDER: ENGINE 58706-4 (29201)		EA	1					4	44
X20		GASKET: CARBURETOR MTG 58537A (29201)		EA	2					5	1
X20		SPACER: CARBURETOR MTG 58780 (29201)		EA	1					5	2
P 0	2910-177-7768	CARBURETOR A59535B (29201)		EA	1	*	*	*	2	5	3
X20		PIN, COTTER: CHOKE ROD AND GOVERNOR LINK 86324 (29201)		EA	2					5	4
X20		ROD, CHOKE A58826 (29201)		EA	1					5	5
X20		COVER, AIR FILTER 58773-5 (29201)		EA	1					5	6
X20		NUT: AIR FILTER COVER A58882 (29201)		EA	1					5	7
X20		RING, RETAINING: AIR FILTER COVER .NUT 58319A (29201)		EA	1					5	8
P 0	2940-982-9397	ELEMENT, AIR FILTER 63589 (29201)		EA	1	2	2	2	6	9	5
X20		GASKET: AIR FILTER BRACKET MTG 58392-1 (29201)		EA	1					5	10
X20		WASHER, LOCK: AIR FILTER BRACKET MTG, No. 10 SCREW SIZE 83046 (29201)		EA	2					5	11
0	5305-360-7666	SCREW, CAP, HEXAGON HEAD: AIR FILTER BRACKET MTG, No. 10-32 THD SIZE, 2-1/4 IN. LG 80481 (29201)		EA	2					5	12
X20		BRACKET: AIR FILTER MTG A58818A (29201)		EA	1					5	13
0	5305-551-0146	SCREW, MACHINE: SPEED ADJUSTING PLATE MTG, No. 8-32 THD SIZE, 1/4 IN. LG 80575 (29201)		EA	2					5	14
X20		PLATE: SPEED ADJUSTING A59299 (29201)		EA	1					5	15
0	5305-682-6023	SCREW, CAP, HEXAGON HEAD: CHAMBER MTG, No. 12-24 THD SIZE, 7/8 IN. LG 80891 (29201)		EA	5					5	16
X20		CHAMBER CARBURETOR A59607 (29201)		EA	1					5	17
X20		PLUG, BUTON: CHAMBER, 3/16 IN. 59787 (29201)		EA	2						
X20		PLUG, BUTTON: CHAMBER, 1/4 IN. 59222 (29201)		EA	1						

(1) SMR CODE	(2) FEDERAL STOCK NUMBER	(3) DESCRIPTION REF NUMBER & MFR CODE	(4) USABLE ON CODE	(5) UNIT MEAS QTY INC IN UNIT	(6) 15-DAY ORGANIZATIONAL MAINTENANCE ALW				(7) ILLUS- TRATION	
					(a)	(b)	(c)	(d)	(a)	(b)
					1-5	6-20	21-50	51-100	FIG NO.	ITEM NO.
X20		PIN, COTTER 86301 (29201)		EA	1					
X20		PLUG, FELT 59329 (29201)		EA	1				5	18
X20		GROMMET: IN CHAMBER 58362 (29201)		EA	1				5	19
X20		BUTTON: CHOKE ROD 57289-1 (29201)		EA	1				5	20
X20		GOVERNOR: AIR VANE A59301A (29201)		EA	1				5	21
0	5305-059-8446	SCREW, MACHINE: GOVERNOR AND REED MTG, No. 4-40 THD SIZE, 3/16 IN. LG 80658 (29201)		EA	4				5	22
X20		LINK: GOVERNOR TO CARBURETOR 59260 (29201)		EA	1				5	23
X20		GROMMET: LOW-HIGH 59058 (29201)		EA	1				5	24
X20		REED 58775 (29201)		EA	1				5	25
X20		BACK-UP, REED 59053 (29201)		EA	1				5	26
X20		STOP, REED 58776 (29201)		EA	1				5	27
X20		SPRING: GOVERNOR 59242 (29201)		EA	1				5	28
X20		CLAMP: THROTTLE ROD 59367 (29201)		EA	1				5	29
X20		ROD, THROTTLE A62935 (29201)		EA	1				5	30
X20		COLLAR: THROTTLE ROD A59285 (29201)		EA	1				5	31
0	5305-005-9748	SETSCREW: THROTTLE ROD COLLAR, No. 4-40 THD SIZE, 1/8 IN. LG 80893 (29201)		EA	1				5	32
0	5310-783-8778	WASHER, FLAT: HIGH-LOW GROMMET MTG, No. 8 SCREW SIZE 84025 (29201)		EA	2				5	33
X20		SPRING: CARBURETOR ADJUSTING SCREW 75892 (29201)		EA	2				5	34
0	5305-558-3858	SCREW, MACHINE: CARBURETOR ADJUSTING, No. 8-32 THD SIZE, 3/8 IN. LG 80577 (29201)		EA	2				5	35
X20		KIT, REPAIR, CARBURETOR 58972 (29201)		EA	1					
X20		GASKET SET, CARBURETOR 58971 (29201)		EA	1					
P 0	4820-168-2065	KIT, REPAIR, VALVE K4211T (98991)		EA	1	*	2	2	2	
		GROUP 02 - BOOM SPRAY SYSTEM								
X20		BOOM SPRAY SYSTEM 3060 (22065)		EA	1				6	1
P 0	1670-179-6251	STRAP ASSEMBLY WB661-1-52N (95957)		EA	2	*	*	2	2	6
P 0	1670-179-6252	STRAP ASSEMBLY WB661-1-25N (95957)		EA	2	*	*	2	2	6

(1) SMR CODE	(2) FEDERAL STOCK NUMBER	(3) DESCRIPTION REF NUMBER & MFR CODE	(4) USABLE ON CODE	(5) UNIT MEAS QTY INC IN UNIT	(6) 15-DAY ORGANIZATIONAL MAINTENANCE ALW				(7) ILLUS- TRATION		
					(a)	(b)	(c)	(d)	(a)	(b)	
					1-5	6-20	21-50	51-100	FIG NO.	ITEM NO.	
P 0	3740-179-6723	BOOM ASSEMBLY, OUTBOARD 3069-11 (22065)		EA	2	*	*	*	2	6	4
P 0	4730-186-7798	NIPPLE: BRASS AN911-2 (81350)		EA	56	2	2	4	8	6	5
P 0	4730-168-2087	PLUG: NYLON 1-4NPT (17224)		EA	56	*	*	2	2	6	6
P 0	4730-168-2086	PLUG 84003-4NPT (82247)		EA	2	*	*	2	2	6	7
P 0	3740-179-6727	STRUT ASSEMBLY 3028 (22065)		EA	2	*	*	*	2	6	8
0	5306-151-0784	BOLT, MACHINE: STRUT ASSEMBLY AND BRACE ASSEMBLY AN3-10A (88044)		EA	4					6	9
0	5310-167-0818	WASHER: STRUT ASSEMBLY, BRACE ASSEMBLY AND CABLE ASSEMBLIES MTG AN960-10 (88044)		EA	18					6	10
X20		NUT, PLAIN, HEXAGON: STRUT ASSEMBLY AND CABLE ASSEMBLY MS20365-1032 (96906)		EA	4					6	11
0	5306-156-2287	BOLT, MACHINE: CLEVIS, STRUT ASSEMBLY AND CABLE ASSEMBLY MTG AN24-18A (88044)		EA	4					6	12
0	5310-141-1795	WASHER: STRUT ASSEMBLY AND CABLE ASSEMBLY MTG AN960-416 (88044)		EA	4					6	13
0	5310-595-7475	NUT: STRUT ASSEMBLY, MS20364-428 (96906)		EA	2					6	14
0	5310-579-0848	NUT: STRUT ASSEMBLY AN316-6 (88044)		EA	2					6	15
P 0	3740-179-6728	ROD, END MD46-16 (73134)		EA	2	*	*	*	2	6	16
P 0	3740-179-6729	CLAMP ASSEMBLY 3031 (22065)		EA	4	*	*	*	2	6	17
X1		CLAMP, HALF: TOP 3031-1 (22065)		EA	1					6	18
X1		CLAMP, HALF: BOTTOM 3031-3 (22065)		EA	1					6	19
0	5306-337-2861	BOLT, MACHINE: CLAMP ASSEMBLY AN3-22A (88044)		EA	4					6	20
0	5310-167-0818	WASHER: CLAMP ASSEMBLY AN960-10 (88044)		EA	4					6	REF
X20		NUT: CLAMP ASSEMBLY MS20365-1032 (96906)		EA	4					6	REF
P 0	3740-179-6726	RING, HALF 3032 (22065)		EA	8	*	*	*	2	6	21
P 0	3740-179-6730	BRACE ASSEMBLY 3029 (22065)		EA	2	*	*	2	2	6	22
X20		BRACE 3029-40 (22065)		EA	1					6	23
P 0	3740-179-6732	FORK 3092-1 (22065)		EA	2	*	2	2	2	6	24
X20		NUT: BRACE ASSEMBLY AND CABLE ASSEMBLIES MTG MS20365-1032C (96906)		EA	1					6	25
P 0	3740-179-6735	CABLE ASSEMBLY: ,AFT 3085-7 (22065)		EA	2	*	*	*	2	6	26

(1) SMR CODE	(2) FEDERAL STOCK NUMBER	(3) DESCRIPTION REF NUMBER & MFR CODE	(4) USABLE ON CODE	(5) UNIT MEAS QTY INC IN UNIT	(6) 15-DAY ORGANIZATIONAL MAINTENANCE ALW				(7) ILLUS- TRATION		
					(a)	(b)	(c)	(d)	(a)	(b)	
					1-5	6-20	21-50	51-100	FIG NO.	ITEM NO.	
0	5306-150-9907	BOLT, MACHINE: CLEVIS, FWD AND AFT CABLE ASSEMBLY AN23-11A (88044)		EA	8					6	27
0	5306-656-0358	BOLT, MACHINE: FWD AND AFT CABLE ASSEMBLY AN3-6A (88044)		EA	4					6	28
P0	3740-179-6734	CABL ASSEMBLY FWD 3085-3 (22065)		EA	2	*	*	*	*	6	29
X20		LINK: FWD CABLE ASSEMBLY 3034 (22065)		EA	4					6	30
P 0	3740-179-6733	CABLE ASSEMBLY: CENTER 3085-1 (22065)		EA	2	*	*	*	2	6	31
0	5306-274-2119	BOLT, MACHINE: CENTER CABLE ASSEMBLY MTG AN3-5A (88044)		EA	2					6	32
0	5310-061-7325	NUTT CENTER CABLE ASSEMBLY MTG MS20365-428C (96906)		EA	2					6	33
X20		FRAME ASSEMBLY, SKID 3095 (22065)		EA	1					7	1
X20		FRAME, LOWER 3095-73 (22065)		EA	1					7	2
X20		FRAME, UPPER 3095-1 (22065)		EA	1					7	3
X20		CLAMP: CHEST MTG 3095-19 (22065)		EA	2					7	4
X20		NUT, PLAIN, HEXAGON: CHEST CLAMP MTG 63NE066 (22065)		EA	8					7	5
X20		STUD: TANK MTG 3095-67 (22065)		EA	4					7	6
0	5302-042-4987	SCREW, MACHINE: TANK .MTG, 1/4-28 THD SIZE, 3/4 IN. LG		EA	1					7	7
X20		STUD: TANK MTG 3095-69 (22065)		EA	4					7	8
X20		NUT, SELF-LOCKING, HEXAGON: TANK MTG MS20365-624 (96906)		EA	4					7	9
X20		STRAP ASSEMBLY 3095-41 (22065)		EA	1					7	10
X20		PLATE: STRAP ASSEMBLY MTG 3095-83 (22065)		EA	1					7	11
X20		SCREW, SELF-TAPPING: STRAP ASSEMBLY PLATE MTG AN530-10-10 (88044)		EA	2					7	12
0	5310-828-8189	NUT, WING: GROUND LOADING SYSTEM MTG, 5/16-18 THD SIZE M535425-41 (96906)		EA	2					7	13
X20		PIN AND LANYARD 3095-81 (22065)		EA	2					7	14
X20		SCREW, MACHINE: P1N AND LAYARD MTG, No. 5-40 THD SIZE, 3-7/8 IN. LG, PHILLIPS HEAD 5-40X3-7-8 (22065)		EA	1					7	15
X20		NUT: ELASTIC STOP, PIN AND LAYARD MTG, No.5-40 THD SIZE 5-40 (22065)		EA	1					7	16
X20		BUMPER 3095-35(22065)		EA	4					7	17

(1) SMR CODE	(2) FEDERAL STOCK NUMBER	(3) DESCRIPTION REF NUMBER & MFR CODE	(4) USABLE ON CODE	(5) UNIT MEAS QTY INC IN UNIT	(6) 15-DAY ORGANIZATIONAL MAINTENANCE ALW				(7) ILLUS- TRATION		
					(a)	(b)	(c)	(d)	(a)	(b)	
					1-5	6-20	21-50	51-100	FIG NO.	ITEM NO.	
X20		BUMPER 3095-37 (22065)		EA	2					7	18
X20		BOLT, TEE: BUMPER 3095-21 (22065)		EA	4					7	19
X20		BOLT, TEE: BUMPER 3095-23 (22065)		EA	2					7	20
X20		BOLT, MACHINE: BUMPER AN20-56A (88044)		EA	6					7	21
X20		NUT, STOP: BUMPER 79NE040 (22065)		EA	6					7	22
X20		NUT, WING: BUMPER 3/8-16 THD SIZE 3-8-16 (22065)		EA	1					7	23
X20	6545-914-3480	CHEST, FIELD		EA	1					7	24
X20		STRAP ASSEMBLY: CHEST MTG 3095-43 (22065)		EA	2					7	25
P 0	1670-179-6250	FITTING, TIE DOWN: TANK MTG 2770-3 (22065)		EA	9	*	*	*	2	7	26
P 0	3740-179-6736	TANK ASSEMBLY 3062 (22065)		EA	1	*	*	*	*	8	
X20		TANK 3010 (22065)		EA	1					8	1
X20		CAP ASSEMBLY: FILLER 2646 (22065)		EA	1					8	2
P 0	3740-179-6337	CAP: FILLER 2646-1 (22065)		EA	1	*	*	*	2	8	3
P 0	3740-179-6738	NECK: FILLER 2643-3 (22065)		EA	1	*	*	*	*	8	4
X20		DOUBLER ASSEMBLY 3059 (22065)		EA	1					8	5
P 0	3740-179-6703	FILLER 3063 (22065)		EA	1	*	*	*	2	8	6
P 0	3740-179-6739	STRAINER 3068 (22065)		EA	1	*	*	*	2	8	7
P 0	3740-179-6679	GASKET: FILLER 3064 (22065)		EA	1	*	*	*	2	8	8
P 0	5306-180-0014	BOLT, MACHINE: FILLER AN525-10R12 (88044)		EA	6					8	9
X20		SUMP 3033 (22065)		EA	1					8	10
X20		GASKET: SUMP 3043 (22065)		EA	1					8	11
X20		DOUBLER: SUMP 3042-1 (22065)		EA	1					8	12
0	5306-151-0785	BOLT, MACHINE: SUMP AND END FITTING ASSEMBLY MTG AN3-7A (88044)		EA	28					8	13
0	5310-167-0818	WASHERS: SUMP FLANGES AND END FITTING ASSEMBLY MTG AN960-10 (88044)		EA	60					8	14
X20		FLANGE 3044-1 (22065)		EA	1					8	15
X20		DOUBLER ASSEMBLY: FLANGE 3045 (22065)		EA	1					8	16

(1) SMR CODE	(2) FEDERAL STOCK NUMBER	(3) DESCRIPTION REF NUMBER & MFR CODE	(4) USABLE ON CODE	(5) UNIT MEAS QTY INC IN UNIT	(6) 15-DAY ORGANIZATIONAL MAINTENANCE ALW				(7) ILLUS- TRATION		
					(a)	(b)	(c)	(d)	(a)	(b)	
					1-5	6-20	21-50	51-100	FIG NO.	ITEM NO.	
0	5306-656-0358	BOLT, MACHINE: FLANGES AND END FITTING ASSEMBLY MTG AN3-6A (88044)		EA	32					8	17
X20		FITTING ASSEMBLY, END 3025 (22065)		EA	2					8	18
X20		DOUBLER ASSEMBLY: END FITTING 3027-3 (22065)		EA	2					8	19
X20		DOUBLER ASSEMBLY: END FITTING 3027-1 (22065)		EA	2					8	20
X20		FLANGE VENT 3074 (22065)		EA	1					8	21
X20		DOUBLER ASSEMBLY: VENT 3076 (22065)		EA	1					8	22
X20		STRAP ASSEMBLY: TANK MTG 3020 (22065)		EA	2					8	23
X20		FELT: STRAP ASSEMBLY 3046 (22065)		EA	1					8	24
0	5306-151-1406	BOLT, MACHINE: STRAP ASSEMBLY MOUNTING AN4-32A (88044)		EA	4					8	25
0	5310-141-1795	WASHER: STRAP ASSEMBLY AND CONTROL SYSTEM AN960-416 (88044)		EA	10					8	26
0	5310-061-7325	NUT: STRAP ASSEMBLY MS20365-428C (96906)		EA	4					8	27
X20		TUBE, VENT: TANK 3060-3 (22065)		EA	1					8	28
X20		ELBOW: VENT TUBE TO TANK AN842-24D (88044)		EA	1					8	29
X20		CLAMP, HOSE: VENT TUBE GS24SS (22065)		EA	2					8	30
0	5340-166-3388	CLAMP, HOSE: VENT TUBE AN742-D28 (88044)		EA	2					8	31
0	5306-274-2119	BOLT, MACHINE: VENT TUBE CLAMP MTG AN3-5A (88044)		EA	2					8	32
0	5310-167-0818	WASHER: VENT TUBE CLAMP MTG AND VALVE MTG AN960-10 (88044)		EA	9					8	REF
X20		NUT: VENT TUBE CLAMP MTG MS20365-1032C (96906)		EA	3					8	33
P 0	4720-541-9266	HOSE ASSEMBLY: VALVE ASSEMBLY TO PUMP ASSEMBLY MS2874-20-0520 (96906)		EA	1	*	*	*	*	8	34
X20		ELBOW, PIPE: AT VALVE ASSEMBLY AND PUMP ASSEMBLY AN823-20D (88044)		EA	2					8	35
P 0	4720-168-2091	HOSE, RUBER: PUMP INLET, 2 IN. ID, 18 IN. LG 8M18 (77988)		EA	1	*	*	*	*	8	36
X20		CLAMP, HOSE: PUMP INLIET HOSE MTG GS32SS (22065)		EA	2					8	37
0	4701-186-9493	NIPPLE: AT VALVE ASSEMBLY AN816-20D (88044)		EA	1					8	38
P 0	4720-143-9262	HOSE ASSEMBLY MS28741-20-0122 (96906)		EA	1	*	*	*	*	8	39
P 0	5330-179-6246	GASKET: VALVE MTG 7407 (22065)		EA	1	*	*	*	2	8	40

(1) SMR CODE	(2) FEDERAL STOCK NUMBER	(3) DESCRIPTION REF NUMBER & MFR CODE	(4) USABLE ON CODE	(5) UNIT MEAS QTY INC IN UNIT	(6) 15-DAY ORGANIZATIONAL MAINTENANCE ALW				(7) ILLUS- TRATION		
					(a)	(b)	(c)	(d)	(a)	(b)	
					1-5	6-20	21-50	51-100	FIG NO.	ITEM NO.	
0	5306-162-2057	BOLT, MACHINE: VALVE MTG AN3H4A (88044)		EA	6					8	41
P0	9505-293-4208	WIRE: SAFETY, VALVE MTG MS20995C32 (96906)		EA	V	*	*	*	*	8	42
X20		HOSE RUBBER: VALVE 3082-3 (22065)		EA	1					8	43
X20		CLAMP, HOSE: VALVE HOSE GS28SS (22065)		EA	2					8	44
P 0	3740-179-6683	FORK, BRAKE 6011 (22065)		EA	1	*	*	2	2	8	45
P 0	3740-179-6684	LINK, BRAKE 3049 (22065)		EA	2	*	*	2	2	8	46
X20		PIN, CLEVIS MS20392-2-17 (96906)		EA	1					8	47
0	5310-167-0834	WASHER AN960-101 (88044)		EA	1					8	48
0	5310-176-8108	NUT, CASTELLATED AN320-4 (88044)		EA	2					8	49
0	5306-156-2695	BOLT, MACHINE AN24-11 (88044)		EA	1					8	50
0	5315-017-9252	PIN, COTTER AN380-2-4 (88044)		EA	2					8	51
X20		BOLT, MACHINE: VALVE AN4-11 (88044)		EA	1					8	52
0	5315-839-5820	PIN, COTTER AN380-2-3 (88044)		EA	1					8	53
X20		HOSE, RUBBER: VALVE 3082-1 (22065)		EA	1					8	54
0	5340-186-3408	CLAMP, HOSE: VENT TUBE AN742-D24 (88044)		EA	2					9	1
X20		SUPPORT ASSEMBLY: TANK 3003 (22065)		EA	1					9	2
X20		CLAMP: SUPPORT ASSEMBLY 3087-1 (22065)		EA	4					9	3
0	5305-208-8262	SCREW: SUPPORT ASSEMBLY AN509-10R10 (88044)		EA	24					9	4
0	5310-167-0818	WASHER: SUPPORT ASSEMBLY AN960-10 (88044)		EA	24					9	5
X20		NUT SUPPORT ASSEMBLY MS20365-1032C (96906)		EA	24					9	6
X20		SUPPORT, PUMP 3030 (22065)		EA	1					9	7
0	5306-274-2119	BOLT, MACHINE: PUMP SUPPORT MTG AND CONTROL SYSTEM AN3-5A (88044)		EA	3					9	8
0	5310-167-0818	WASHER: PUMP, SUPPORT, STATUS, BRACKET, CONTROL SYSTEM AND HANDLES MTG AN960-10 (88044)		EA	25					9	REF
X20		NUT: PUMP SUPPORT STRUTS, BRACKET, FITTING AND CONTROL SYSTEM MTG M20365-1032C (96906)		EA	13					9	REF
0	5306-180-1483	BOLT, MACHINE: PUMP ASSEMBLY MTG AN6-11A (88044)		EA	2					9	9
0	5310-167-0821	WASHER: PUMP ASSEMBLY AND CONTROL SYSTEM MTG AN960-616 (88044)		EA	4					9	10

(1) SMR CODE	(2) FEDERAL STOCK NUMBER	(3) DESCRIPTION REF NUMBER & MFR CODE	(4) USABLE ON CODE	(5) UNIT MEAS QTY INC IN UNIT	(6) 15-DAY ORGANIZATIONAL MAINTENANCE ALW				(7) ILLUS- TRATION		
					(a)	(b)	(c)	(d)	(a)	(b)	
					1-5	6-20	21-50	51-100	FIG NO.	ITEM NO.	
X20		NUT: PUMP ASSEMBLY MTG MS20365-624C (96906)		EA	2					9	11
0	5306-209-2648	BOLT, EYE: PUMP ASSEMBLY MTG AN43B10A (88044)		EA	2					9	12
X20		BUSHING: PUMP ASSEMBLY NAS75-4-010 (22065)		EA	2					9	13
0	5310-167-0766	WASHER: PUMP ASSEMBLY AND TUBE ASSEMBLY MTG AN970-4 (88044)		EA	10					9	14
0	5310-061-7325	NUT: PUMP ASSEMBLY, STRUT AND TUBE ASSEMBLY MTG MS20365-428C (96906)		EA	15					9	15
0	370-179-6740	STRUT, SUPPORT: PUMP, FWD 3039-1 (22065)		EA	1	*	*	*	*	9	16
0	5306-151-0784	BOLT, MACHINE: STRUTS MTG AN3-10A (88044)		EA	4					9	17
P 0	3740-179-6701	STRUT, SUPPORT: PUMP, AFT 3039-3 (22065)		EA	1	*	*	*	*	9	18
0	5306-271-6864	BOLT, EYE AN43B4A (88044)		EA	1					9	19
0	5310-141-1795	WASHER: STRUT, TUBE ASSEMBLIES, CLAMP ASSEMBLY, FITTING AND CONTROL SYSTEM MTG AN960-416 (88044)		EA	19					9	20
X20		BRACKET 3047 (22065)		EA	1					9	21
0	5306-725-1908	BOLT, MACHINE BRACKET MTG AN3-30A (88044)		EA	2					9	22
X20		PAN: DRIP 3077 (22065)		EA	1					9	23
X20		TUBE ASSEMBLY: PUMP TO SUMP 3055-1 (22065)		EA	1					9	24
0	5306-151-1406	BOLT, MACHINE: TUBE ASSEMBLIES AND CLAMP ASSEMBLY MTG AN4-32A (88044)		EA	12					9	25
X20		HOSE, RUBBER: SUMP TO TUBE ASSEMBLIES 3038 (22065)		EA	2					9	26
X20		CLAMP, HOSE: SUMP TO TUBE ASSEMBLY HOSE GS32SS (22065)		EA	4					9	27
P 0	3740-179-6725	TUBE ASSEMBLY 3055-3 (22065)		EA	1	*	*	*	*	9	28
X20		BUSHING: TUBE ASSEMBLIES 3051 (22065)		EA	12					9	29
X20		NIPPLE: TUBE ASSEMBLY AVHN24-24F (22065)		EA	1					9	30
X20		CAP, DUST: TUBE ASSEMBLY ADCH24 (22065)		EA	1					9	31
0	4730-287-0263	ELBOW AN823-21D (88044)		EA	1					9	32
P 0	3740-179-6724	BOOM ASSEMBLY: CENTER 3070 (22065)		EA	1	*	*	*	*	9	33
0	4730-278-3678	ELBOW: CENTER BOOM AN822-5D (88044)		EA	1					9	34
X20		CLAMP ASSEMBLY: CENTER BOOM MTG 3048 (22065)		EA	2					9	35
X1		CLAMP, HALF 3048-1 (22065)		EA	1						

(1) SMR CODE	(2) FEDERAL STOCK NUMBER	(3) DESCRIPTION REF NUMBER & MFR CODE	(4) USABLE ON CODE	(5) UNIT MEAS QTY INC IN UNIT	(6) 15-DAY ORGANIZATIONAL MAINTENANCE ALW				(7) ILLUS- TRATION		
					(a)	(b)	(c)	(d)	(a)	(b)	
					1-5	6-20	21-50	51-100	FIG NO.	ITEM NO.	
X1		CLAMP, HALF 3048-3 (22065)		EA	1						
0	5310-061-7325	NUT: CLAMP ASSEMBLY MS20365-428C (96906)		EA	2				9	REF	
0	5310-141-1795	WASHER: CLAMP ASSEMBLY AN960-416 (88044)		EA(A)	2				9	REF	
0	5306-151-1424	BOLT: CLAMP ASSEMBLY AN4-10A (88044)		EA	2				9	36	
X20		FITTING NAS1211B15 (22065)		EA	4				9	37	
X20		CLAMP: CONTROL SYSTEM MS21919-8 (96906)		EA	1				9	38	
0	5310-579-0848	NUT: CONTROL SYSTEM AN316-6 (88044)		EA	2				9	39	
X20		HANDLE SS6 (22065)		EA	8				9	40	
0	5306-722-0393	BOLT, MACHINE: HANDLE MTG AN3-4A (88044)		EA	16				9	41	
X20		WASHER, LOCK: HANDLE MTG AN936-10 (88044)		EA	16				9	42	
P 0	4720-143-9264	HOSE ASSEMBLY: PRESSURE GAGE MS28741-5-0720 (96906)		EA	1	*	*	*	2	9	43
0	5306-151-1426	BOLT, MACHINE: CONTROL SYSTEM AN4-6A (88044)		EA	2				9	44	
X20		NUT: CONTROL SYSTEM MS20365-428 (96906)		EA	2				9	45	
P 0	3740-179-6680	PANEL ASSEMBLY, CONTROL SYSTEM, MANUAL 3091 (22065)		EA	1	*	*	*	*	10	1
P 0	3740-179-6681	SUPPORT ARM ASSEMBLY, HINGED 3091-40 (22065)		EA	1	*	*	*	*	10	2
X20		CONTROL ASSEMBLY 3091-50 (22065)		EA	1				10	3	
X20		SCREW, MACHINE: CONTROL TO SUPPORT MTG M31CR420-10E2 (22065)		EA	6				10	4	
X20		NUT WING: CONTROL TO SUPPORT MTG, 1/4-20 THD SIZE 1-4-20NC2CRES (22065)		EA	2				10	5	
0	5306-151-1426	BOLT, MACHINE: HINGE STIFFNER MTG AN4-6A (88044)		EA	2				10	6	
0	5310-141-1795	WASHER: HINGE STIFFNER MTG AN960-416 (88044)		EA	2				10	7	
X20		NUT: HINGE STIFFNER MTG MS20365-428 (96906)		EA	2				10	8	
X20		STIFFNER, HINGE 3091-21 (22065)		EA	1				10	9	
X20		LEVER, VALVE 6008-3 (22065)		EA	1				10	10	
X20		LEVER, BRAKE 6008 (22065)		EA	1				10	11	
0	5306-151-1282	BOLT, MACHINE: LEVERS MTG AN5-15A (88044)		EA	4				10	12	
0	5310-167-0820	WASHER: LEVERS MTG AN960-516 (88044)		EA	4				10	13	
0	5310-050-3345	NUT: LEVERS MTG MS20365-524 (96906)		EA	4				10	14	

(1) SMR CODE	(2) FEDERAL STOCK NUMBER	(3) DESCRIPTION REF NUMBER & MFR CODE	(4) USABLE ON CODE	(5) UNIT MEAS QTY INC IN UNIT	(6) 15-DAY ORGANIZATIONAL MAINTENANCE ALW				(7) ILLUS- TRATION		
					(a)	(b)	(c)	(d)	(a)	(b)	
					1-5	6-20	21-50	51-100	FIG NO.	ITEM NO.	
P 0	3740-179-6682	CABLE ASSEMBLY, BRAKE 6009-5 (22065)		EA	1	*	*	*	*	10	15
P 0	3740-179-6686	ROD, CONNECTING: VALVE, SHORT 3091-5 (22065)		EA	1	*	*	*	*	10	16
P 0	3740-179-6687	ROD, CONNECTING: VALVE, LONG 3091-7 (22065)		EA	1	*	*	*	*	10	16
P 0	3740-179-6688	FORK: VALVE END 3091-17 (22065)		EA	1	*	*	*	2	10	17
P 0	3740-179-6690	FORK: CONTROL END 3091-19 (22065)		EA	1	*	*	*	2	10	18
P 0	6685-883-1808	GAGE, PRESSIRE FIG45-150X30 (72100)		EA	1	*	*	*	*	10	19
X20		WASHER: PRESSURE GAGE MTG 2068 (22065)		EA	2					10	20
0	5310-176-0825	WASHER: PRESSURE GAGE MTG AN960-1016 (88044)		EA	1					10	21
0	4730-278-2682	COUPLING: PRESSURE GAGE MTG AN910-2D (88044)		EA	1					10	22
0	4730-196-9585	NIPPLE: GAGE MTG AN816-5-4D (88044)		EA	1					10	23
P 0	3740-179-6741	VALVE ASSEMBLY: THD, 1-1/2 IN. NPT 7400-1 (22065) (Components same as VALVE ASSEMBLY,FSN 3740-179-6720, EXCEPT WHERE INDIVIDUAL ITEMS ARE ANNOTATED)		EA	1	*	*	*	*	11	1
P 0	3740-179-6720	VALVE ASSEMBLY: HOSE FITTINGS 7400 (22065)		EA	1	*	*	*	*	11	1
X1		BODY, VALVE: HOSE 7401 (22065) (U/o VALVE ASSEMBLY, FSN 3740-179-6720, ONLY)		EA	1					11	2
X1		BODY, VALVE: THD PIPE 7401-1 (22065) (U/o VALVE ASSEMBLY, FSN 3740-179-6741, ONLY)		EA	1					11	3
X20		FLAPPER 7406 (22065)		EA	1					11	4
X20		ROTOR 7404 (22065)		EA	1					11	5
X1		SEAL 7409 (22065) (Component of KIT, FSN 3740-179-6721)		EA	2					11	6
X1		GASKET 7307 (22065) (Component of KIT, FSN 3740-179-6721)		EA	2					11	7
X20		CAP 7402 (22065)		EA	1					11	8
X1		BEARING 3711 (22065) (Component of KIT, FSN 3740-179-6721)		EA	2					11	9
X20		CAP: SHAFT END 7403 (22065)		EA	1					11	10
X20		SCREW: FLOW CONTROL 7313 (22065)		EA	1					11	11

(1) SMR CODE	(2) FEDERAL STOCK NUMBER	(3) DESCRIPTION REF NUMBER & MFR CODE	(4) USABLE ON CODE	(5) UNIT MEAS QTY INC IN UNIT	(6) 15-DAY ORGANIZATIONAL MAINTENANCE ALW				(7) ILLUS- TRATION		
					(a)	(b)	(c)	(d)	(a)	(b)	
					1-5	6-20	21-50	51-100	FIG NO.	ITEM NO.	
X1		RING, QUAD 7210 (22065) (Component of KIT, FSN 3740-179-6721)		EA	2					11	12
0	5306-266-4102	BOLT MACHINE: CAPS .MTG TO BODY, 1/4-20 THD SIZE, 5/8 IN. LG		EA	8					11	13
X20		LEVER, CONTROL 7208 (22065)		EA	1					11	14
0	5310-167-0818	WASHER: CONTROL LEVER MTG AN960-10 (88044)		EA	1					11	15
X20		BOLT, MACHINE: CONTROL LEVER MTG AN3-13A (88044)		EA	1					11	16
X20		NUT, PLAIN, HEXAGON: CONTROL LEVER MTG AN365-1032 (88044)		EA	1					11	17
X1		PACKING, PREFORMED 568-011 (22065) (Component of KIT, FSN 3740-179-6721)		EA	1					11	18
X20		SEAT 7419 (22065)		EA	2					11	19
X1		WASHER, THRUST 7310 (22065) (Component of KIT, FSN 3740-179-6721)		EA	1					11	20
X1		WASHER, FLAT 7416 (22065) (Component of KIT, FSN 3740-179-6721)		EA	2					11	21
X1		NUT AN363C1032 (88044) (Component of KIT, FSN 3740-173-6721)		EA	1					11	22
X1		SCREW AN525C10R12 (88044) (Component of KIT, FSN 3740-179-6721)		EA	1					11	23
X1		PIN, STRAIGHT, HEADLESS 7417-1 (22065) (Component of KIT, FSN 3740-179-6721)		EA	1					11	24
P 0	3740-179-6704	WINDMILL ASSEMBLY 6645 (22065)		EA	1	*	*	*	*	12	1
P 0	3740-179-6705	HUB, BASE 6647 (22065)		EA	1	*	*	*	*	12	2
P 0	3740-179-6706	CAP, HUB 6648 (22065)		EA	1	*	*	*	2	12	3
P 0	3740-179-6707	ACTUATOR 6652 (22065)		EA	1	*	*	2	2	12	4
P 0	3740-179-6708	SCREW ADJUSTING 6653 (22065)		EA	1	*	*	*	2	12	5
P 0	5310-797-3615	NUT, ACORN 6672 (22065)		EA	1	*	2	2	4	12	6
X20		PIN, ROLL MS9048-008 (96906)		EA	1					12	7
0	5310-167-0837	WASHER AN960-616L (88044)		EA	2					12	8
P 0	5306-795-3280	BOLT, MACHINE LP3-22A (02615)		EA	3	*	2	2	4	12	9

(1) SMR CODE	(2) FEDERAL STOCK NUMBER	(3) DESCRIPTION REF NUMBER & MFR CODE	(4) USABLE ON CODE	(5) UNIT MEAS QTY INC IN UNIT	(6) 15-DAY ORGANIZATIONAL MAINTENANCE ALW				(7) ILLUS- TRATION		
					(a)	(b)	(c)	(d)	(a)	(b)	
					1-5	6-20	21-50	51-100	FIG NO.	ITEM NO.	
P 0	3740-179-6709	BLADE WINDMILL 6649 (22065)		EA	6	*	2	2	2	12	10
P 0 R	3740-179-6710	PUMP AND BRAKE ASSEMBLY 6330-3 (22065)		EA	1	*	*	*	*	13	1
X20		INLET 6313 (22065)		EA	1					13	2
P 0	3740-179-6711	GASKET: INLET MTG 6642 (22065)		EA	1	*	2	2	2	13	3
0	5305-018-1061	SCREW, CAP, HEXAGON HEAD: INLET .MTG, 1/4-20 THD SIZE, 5/8 IN. LG		EA	6					13	4
0	5310-141-1795	WASER: INLET MTG, 5/8 IN. SCREW SIZE AN960-416 (88044)		EA	6					13	5
P 0	3740-179-6712	DRUM, BRAKE 6655 (22065)		EA	1	*	*	*	*	13	6
0	5315-616-5521	KEY, WOODRUFF MS35756-13 (96906)		EA	1					13	7
P 0	5340-143-0335	RING, SNAP 5160-66 (22065)		EA	2	*	2	2	4	13	8
P 0	3740-179-6675	PLATE, BACK 6654-2 (22065)		EA	1	*	*	*	2	13	9
X20		SCREW, CAP, SOCKET HEAD: BACK PLATE MTG, 1/4-20 THD SIZE, 1/2 IN. LG 1-4X20X1-2 (02615)		EA	3					13	10
P 0	3740-179-6676	SHOE, BRAKE 6654-3 (22065)		EA	2	*	*	2	2	13	11
P 0	5340-178-1369	SPRING, BRAKE SHOE 6654-4 (22065)		EA	1	*	*	2	2	13	12
P 0	5340-622-1799	RETAINER, BRAKE SHOE 5133-37 (79136)		EA	1	*	2	2	2	13	13
P 0	3740-179-6713	PUMP ASSEMBLY 6300T5 (22065)		EA	1	*	*	*	*	13	14
P 0	3740-179-6713	CASE PUMP 6303-5 (22065)		EA	1	*	*	*	*	14	1
P 0	3740-179-6715	GASKET: BODY TO CASE MTG 6306 (22065)		EA	1	*	2	2	4	14	2
P 0	3740-1179-6716	IMPELLER 6302 (22065)		EA	1	*	*	*	*	14	3
P 0	3740-179-6717	BODY, PUMP 6301 (22065)		EA	1	*	*	*	*	14	4
P 0	3740-179-6719	SHAFT: PUMP 6305 (22065)		EA	1	*	*	*	*	14	5
P 0	3740-179-7259	BEARING 99203 (29337)		EA	2	*	2	2	2	14	6
P 0	5340-804-9746	RING, SNAP: BEARING RETAINING N5000-156 (79136)		EA	2	*	2	2	4	14	7
P 0	5340-143-0335	RING, SNAP 5160-66 (79136)		EA	2	REF	REF	REF	REF	14	8
P 0	5330-179-6248	SEAL ASSEMBLY: TEFLON 6308T (99189)		EA	1	*	*	2	2	14	9
X20		PIN, STRAIGHT, HEADLESS 66099 (22065)		EA	1					14	10
0	5305-882-8260	SCREW, CAP, HEXAGON HEAD: BODY TO CASE MTG, 5/16-18 THD SIZE, 3/4 IN. LG		EA	6					14	11

(1) SMR CODE	(2) FEDERAL STOCK NUMBER	(3) DESCRIPTION REF NUMBER & MFR CODE	(4) USABLE ON CODE	(5) UNIT MEAS QTY INC IN UNIT	(6) 15-DAY ORGANIZATIONAL MAINTENANCE ALW				(7) ILLUS- TRATION		
					(a)	(b)	(c)	(d)	(a)	(b)	
					1-5	6-20	21-50	51-100	FIG NO.	ITEM NO.	
0	5310-167-0820	WASHER, LOCK: BODY TO CASE MTG, 5/16 IN. SCREW SIZE AN960-516 (88044)		EA	6					14	12
P 0	5310-531-9515	WASHER, LOCK AN9600416 (88044)		EA	1	*	*	2	2	14	13
P 0	5306-156-2338	BOLT, MACHINE AN406A (88044)		EA	1	*	*	2	2	14	13
0	4730-424-0894	PLUG, PIPE: CASE, 1/8-27 NPT		EA	1					14	15
P 0		NOZZLE ASSEMBLY 4664ALEF (82247)	A	EA	32	*	2	3	6	15	1
X20		CAP, TEEJET 1325AL (82247)	A	EA	1					15	2
P 0		ORIFICE, DISC D6 (82247)	A	EA	1	*	2	3	6	15	3
P 0		ORIFICE, DISC D8 (82247)	A	EA	1	*	2	3	6	15	3
P 0		ORIFICE, DISC D10 (82247)	A	EA	1	*	2	3	6	15	3
P 0		CORE: NOZZLE 56 (82247)	A	EA	1	*	2	3	6	15	4
P 0		CORE: NOZZLE 45 (82247)	A	EA	1	*	2	3	6	15	4
X20		BODY, NOZZLE 46182ASB (82247)	A	EA	1					15	5
P 0	3740-179-6699	DIAPHRAGM, VITON 4620VI (82247)	A	EA	1	32	80	160	336	15	6
P 0	3740-179-6700	DIAPHRAGM, TEFLON 6227 (82247)	A	EA	1	32	80	160	336	15	7
P 0		CAP SUB-ASSEMBLY, END 9758ASB (82247)	A	EA	1	*	2	3	6	15	8
X1		RING, SNAP 4821SS (82247)	A	EA	1					15	9
X1		RETAINER, SPRING 8526NYL (82247)	A	EA	1					15	10
X1		SPRING, HELICAL, COMPRESSION 4632SS (82247)	A	EA	1					15	11
X1		CAP, END 4623ALEF (82247)	A	EA	1					15	12
P 0		RETAINER 4624AL (82247)	A	EA	1	*	2	3	6	15	13
X20		NIPPLE W3325-4-2 (82247)	A	EA	1					15	14
P 0	3740-179-6692	NOZZLE ASSEMBLY 8355 (82247)	B	EA	56	*	2	4	7	16	1
X20		CAP, TEEJET 1325AL (82247)	B	EA	1					16	2
P 0	3740-179-6696	TIP, NOZZLE 2530 (82247)	B	EA	1	2	4	7	14	16	3
P 0	3740-179-6695	TIP, NOZZLE 2510 (82247)	B	EA	1	2	4	7	14	16	3
P 0	3740-179-6698	TIP, NOZZLE 2560 (82247)	B	EA	1	2	4	7	14	16	3
X20		BODY NOZZLE 8296ASB1-4 (82247)	B	EA	1					16	4

(1) SMR CODE	(2) FEDERAL STOCK NUMBER	(3) DESCRIPTION REF NUMBER & MFR CODE	USABLE ON CODE	(4) UNIT MEAS	(5) QTY INC IN UNIT	(6) 15-DAY ORGANIZATIONAL MAINTENANCE AL W				(7) ILLUS- TRATION	
						(a)	(b)	(c)	(d)	(a)	(b)
						1-5	6-20	21-50	51-100	FIG NO.	ITEM NO.
P 0	3740-179-6699	DIAPHRGM, VITON 4620VI (82247)	B	EA	1	4	10	20	42	16	6
0	3740-179-6693	CAP SUB-ASSEMBLY, END 9758NYL (82247)	B	EA	1	2	2	4	6	16	6
X1		RING, SNAP 4821SS (82247)	B	EA	1					16	7
X1		RETAINER. SPRING 8526NYL (82247)	B	EA	1					16	8
X1		SPRING, HELICAL, COMPRESSION 4622SS (82247)	B	EA	1					16	9
X1		CAP, END: NYLON 8522NYL (82247)	B	EA	1					16	10
P 0	3740-179-6694	RETAINER: ALUMINUM 8476AL (82247)	B	EA	1	2	2	4	8	16	11
0	3740-179-6721	KIT, REPAIR, VALVE K7400 (22065)		EA	2	*	*	2	2		
		2-RING, QUAD: 7210 (22065)				REF	REF	REF	REF		
		2-GASKET: 7307 (22065)				REF	REF	REF	REF		
		1-WASHER, THRUST: 7310 (22065)				REF	REF	REF	REF		
		2 BEARING: 7311 (22065)				REF	REF	REF	REF		
		2-SEAL: 7409 (22065)				RLF	REF	REF	REF		
		2-WASHER: 7416 (22065)				REF	REF	REF	REF		
		1-PIN: 7417-1 (22065)				REF	REF	REF	REF		
		1-PACKING, PREFORMED: 568-011 (22065)				REF	REF	REF	REF		
		1-NUT: AN363C1032 (88044)				REF	REF	REF	REF		
		1-SCREW: AN526C10R12 (88044)				REF	REF	REF	REF		

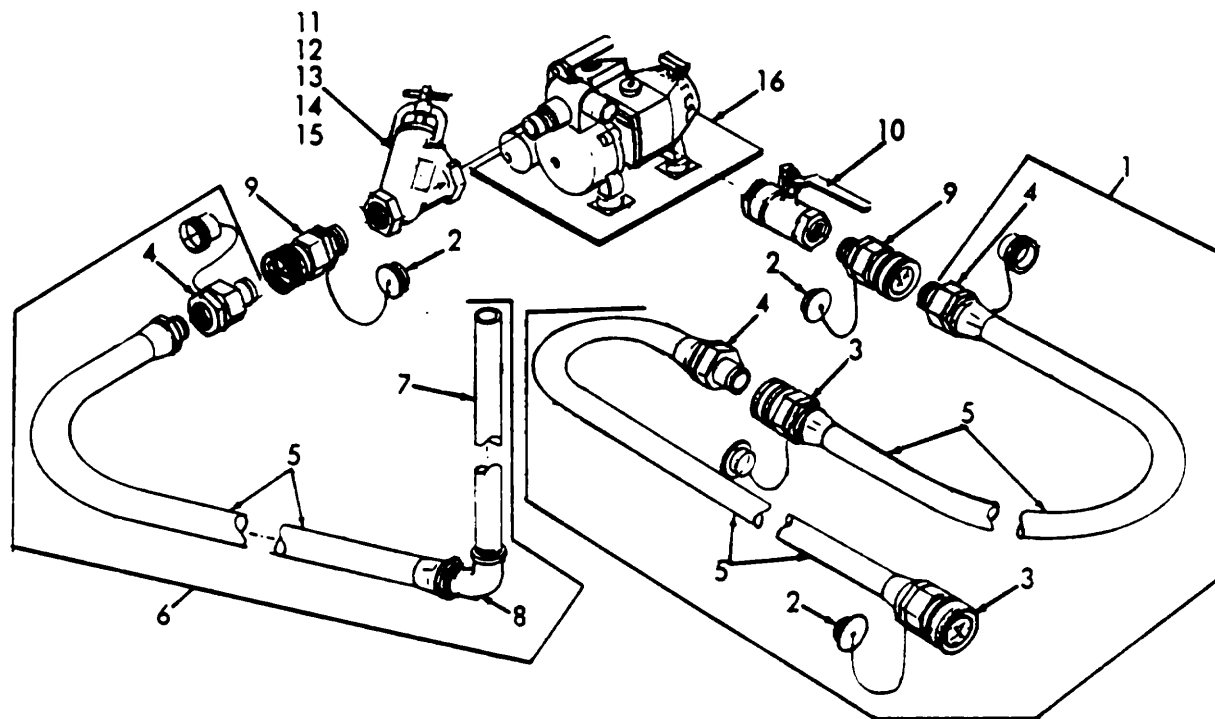

ME 3740-210-20P/1

Figure No. 1 Ground Loading Hoses, Lines And Fittings

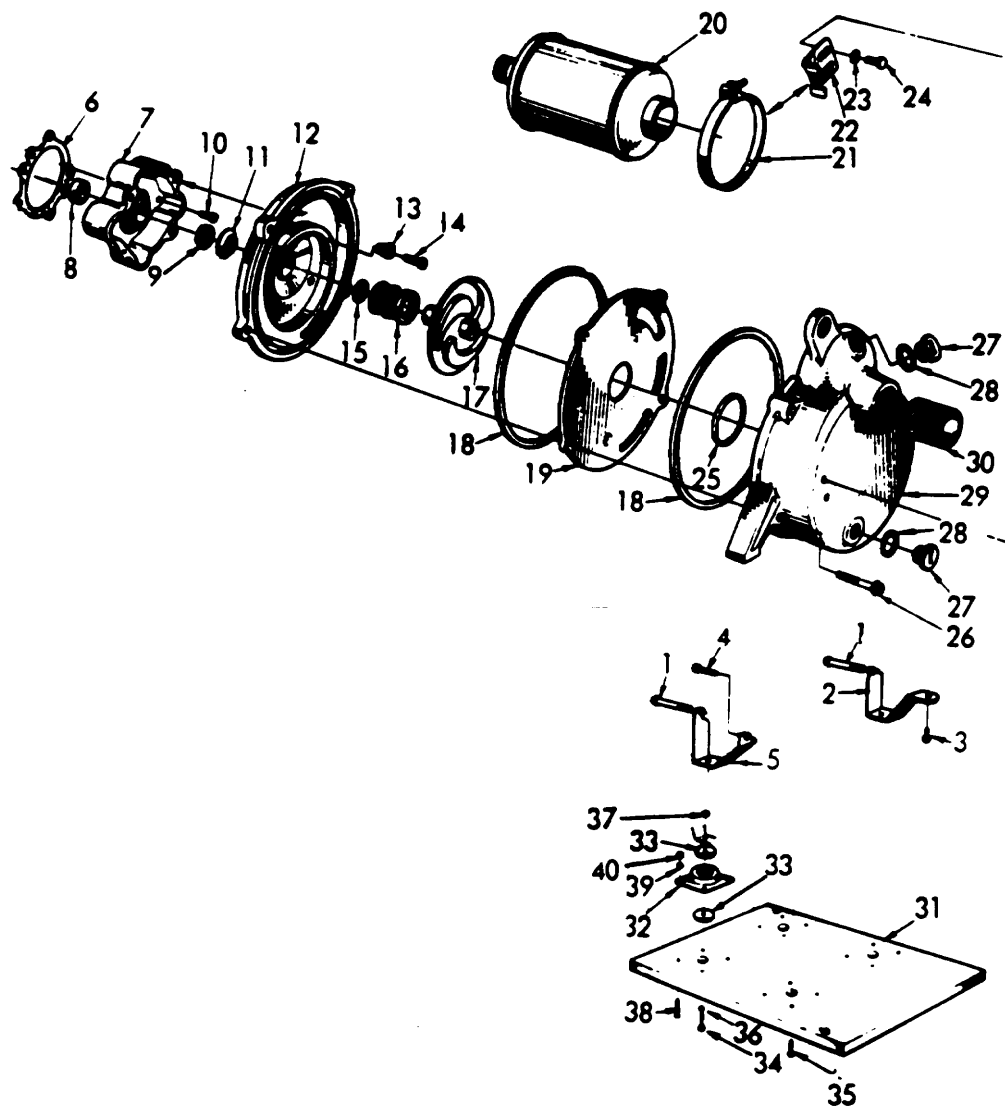

ME 3740-210-20P/2

Figure No. 2 Pump

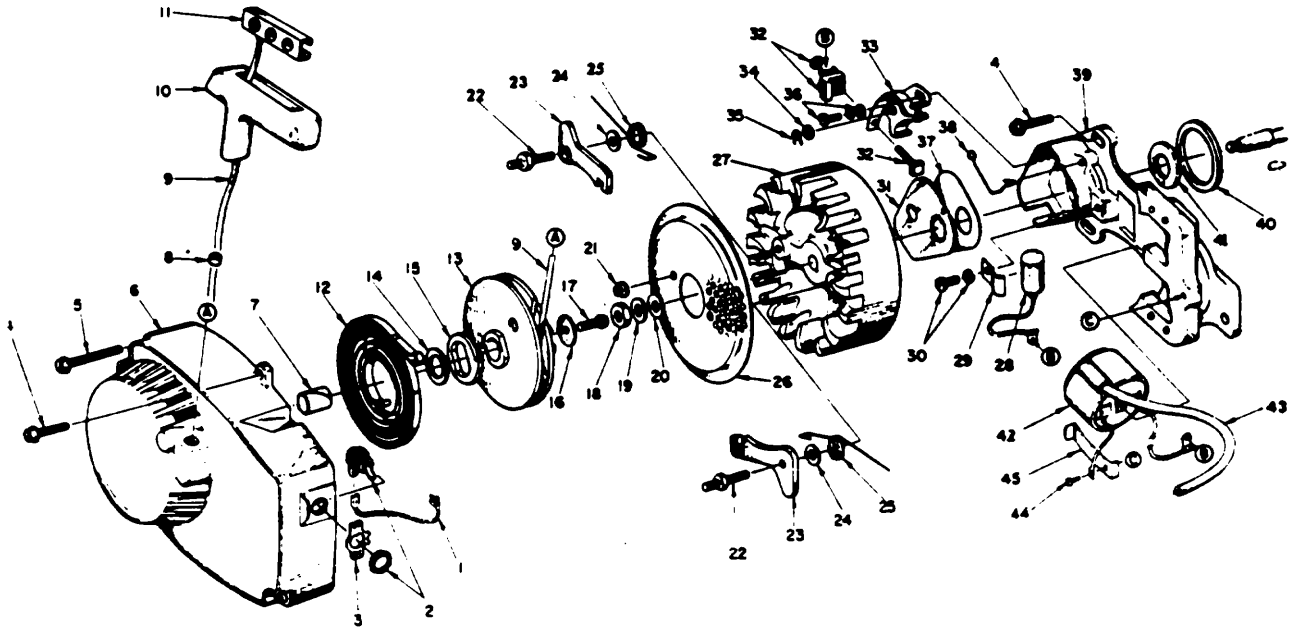

ME 3740-210-20P/2

Figure No. 3 Engine Starting Components

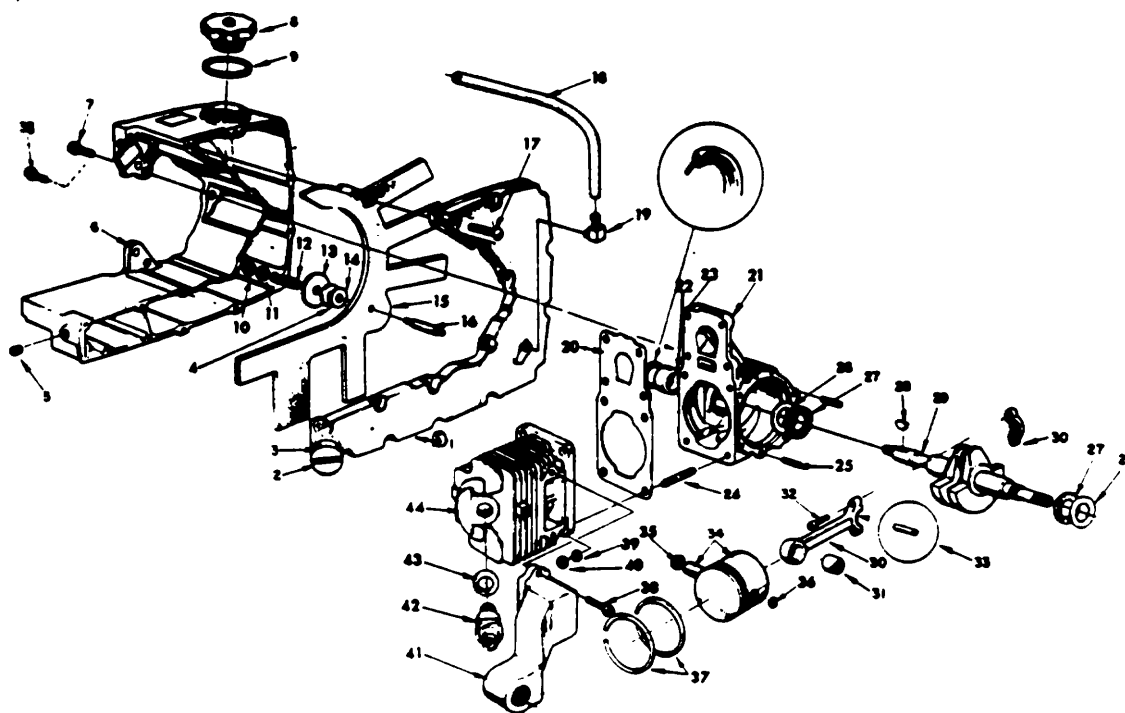

ME 3740-210-20P/4

Figure No. 4 Engine And Gas Tank

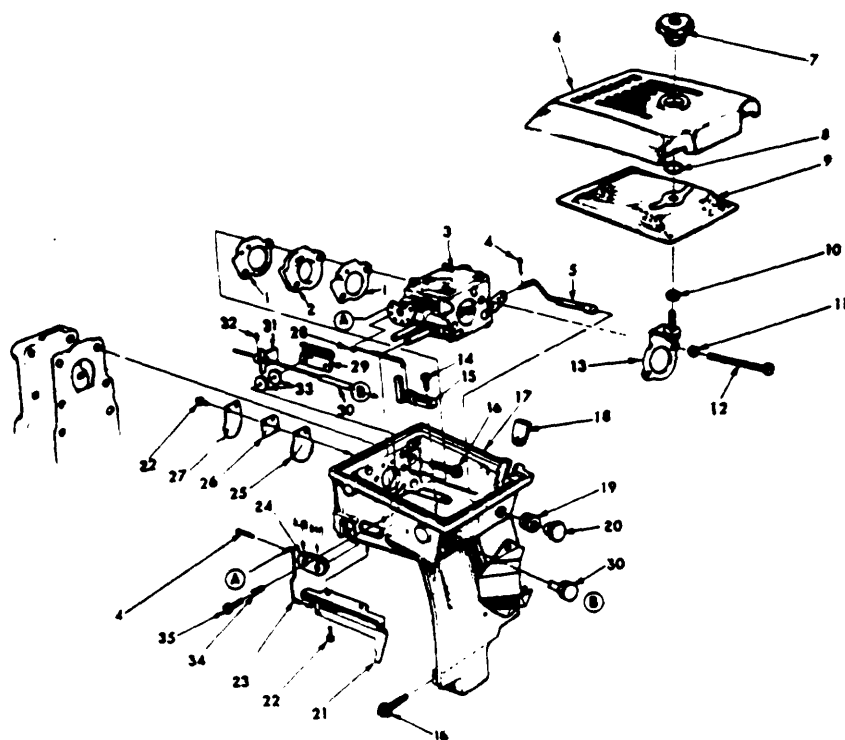

ME 3740-210-20P/5

Figure No. 5 Carburetor, Governor And Related Parts

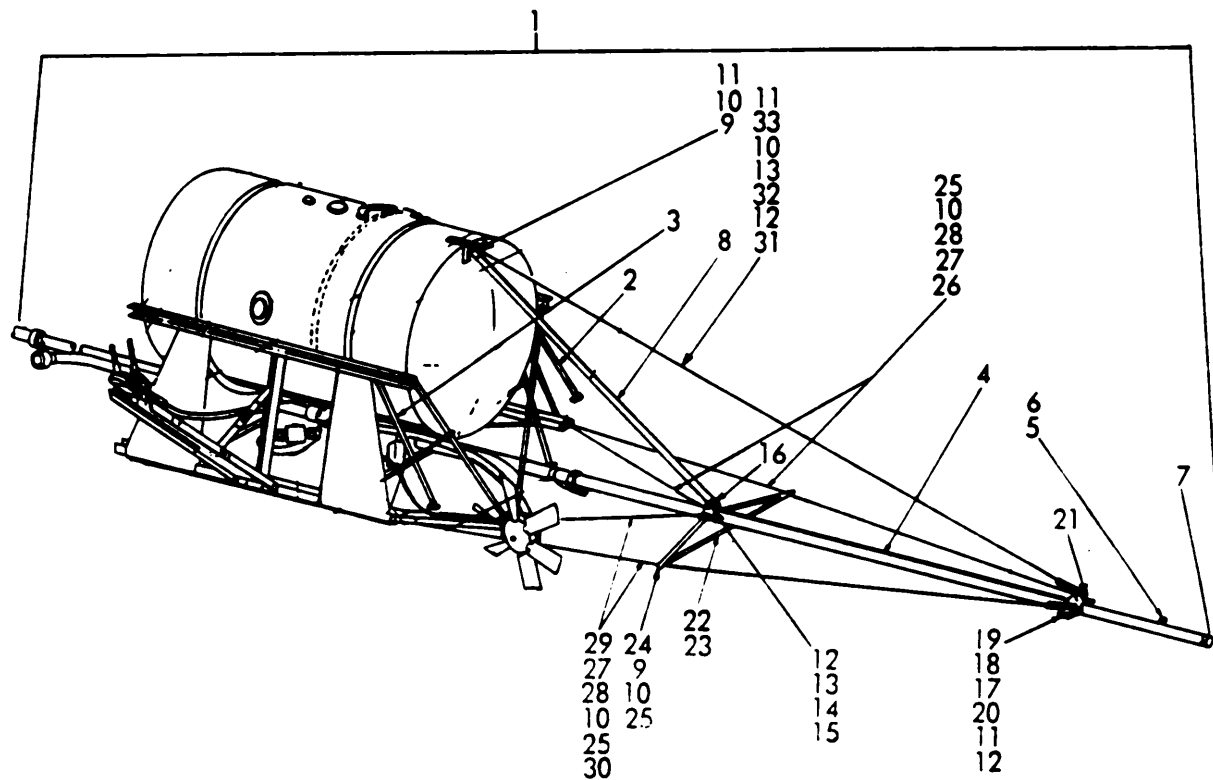

ME 3740-210-20P/6

Figure No. 6 Boom Spray System And Related Parts

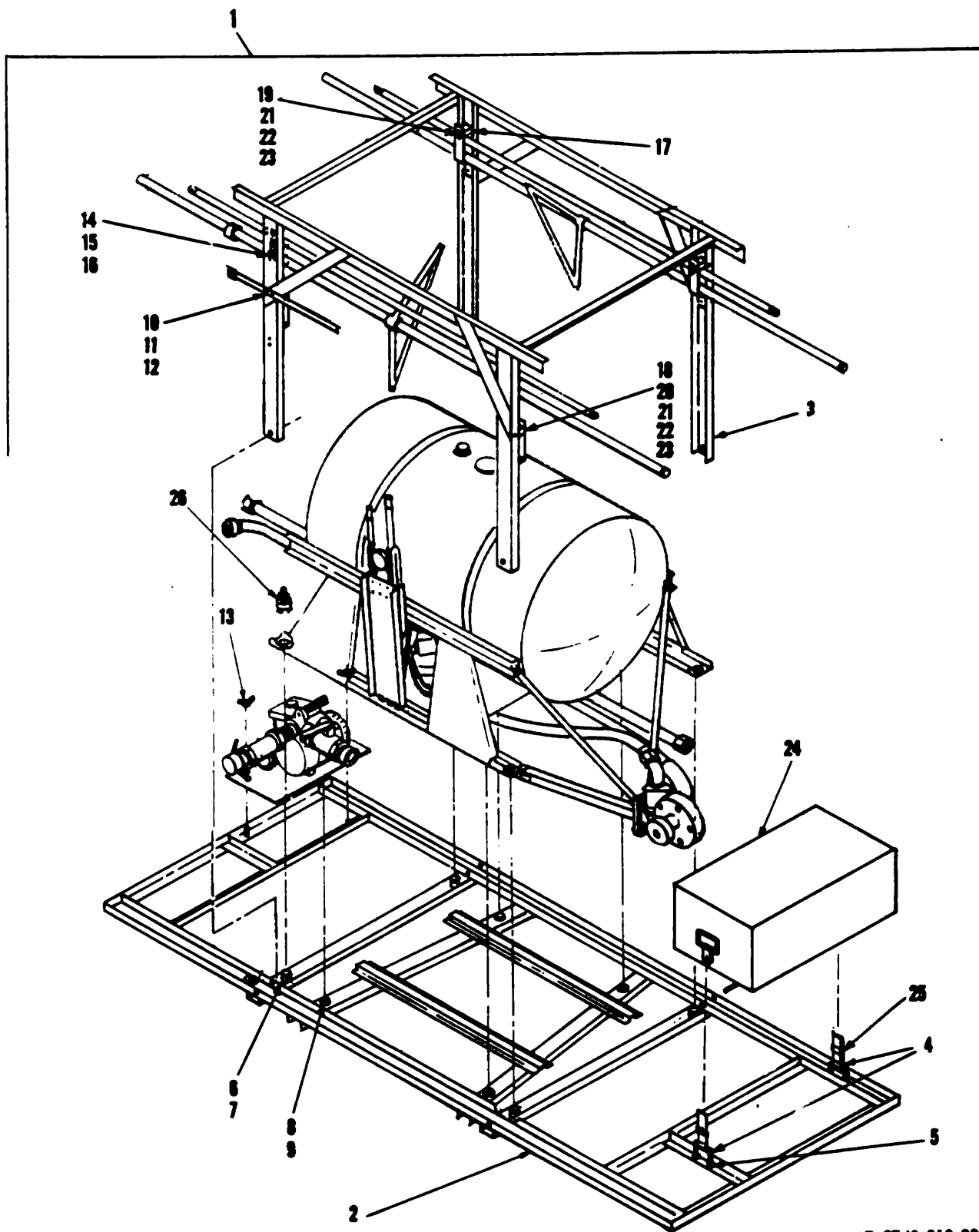

ME 3740-210-20P/7

Figure No. 7 Frame And Related Parts

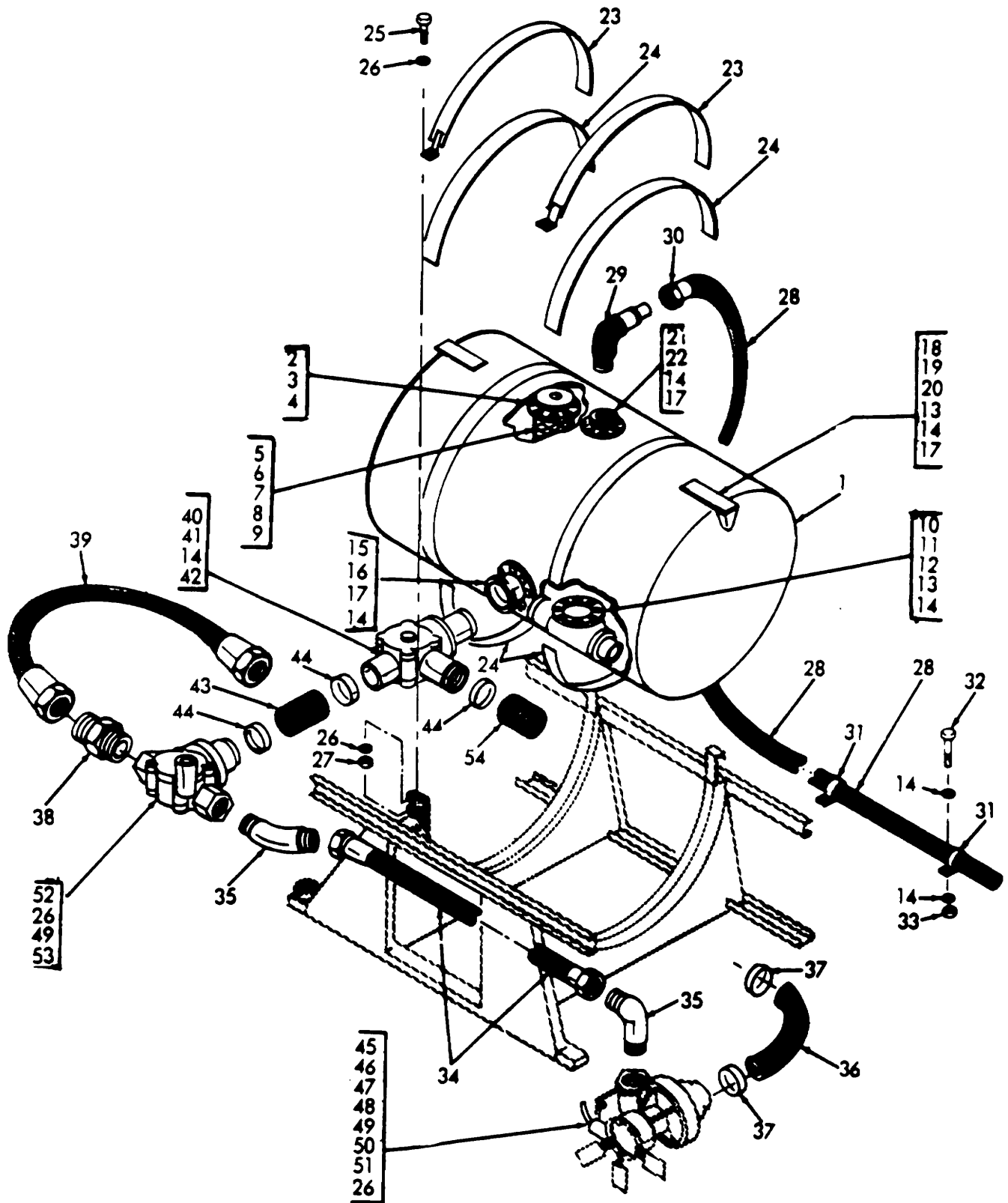

ME 3740-210-20P/R

Figure No. 8 Spray Tank And Related Parts
28

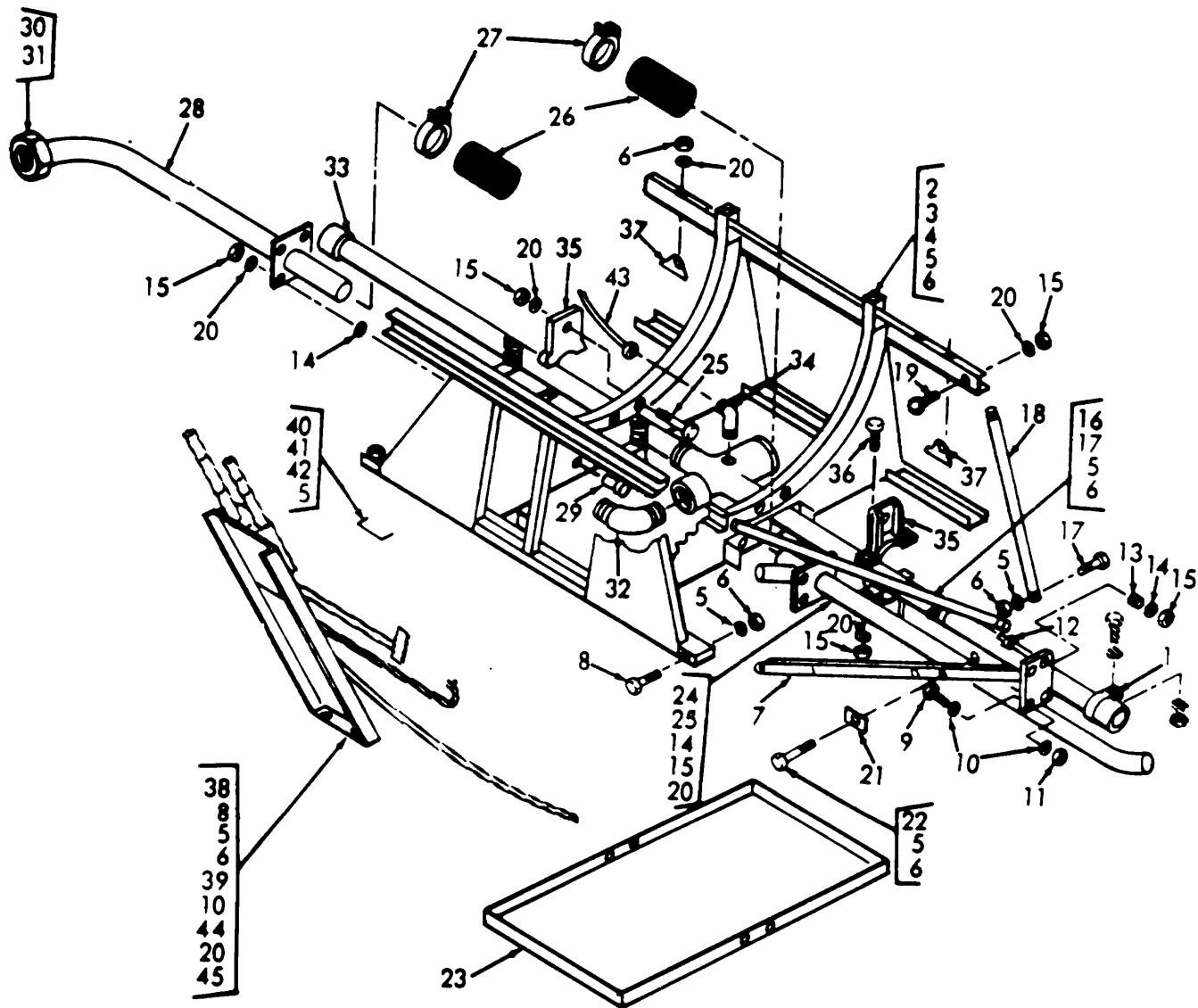

ME 3740-210-20P/9

Figure No. 9 Spray Tank Components

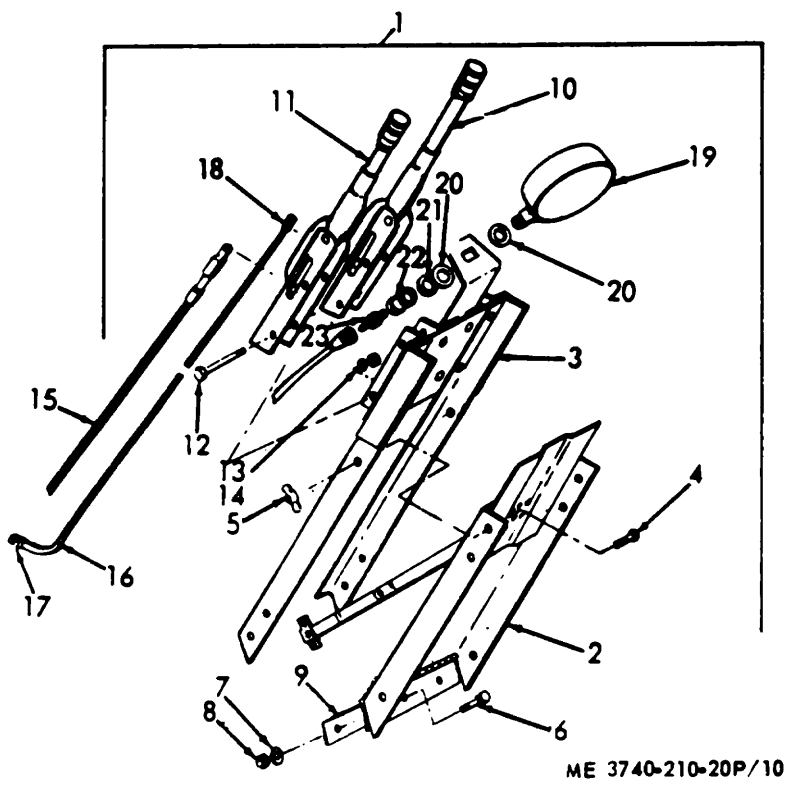
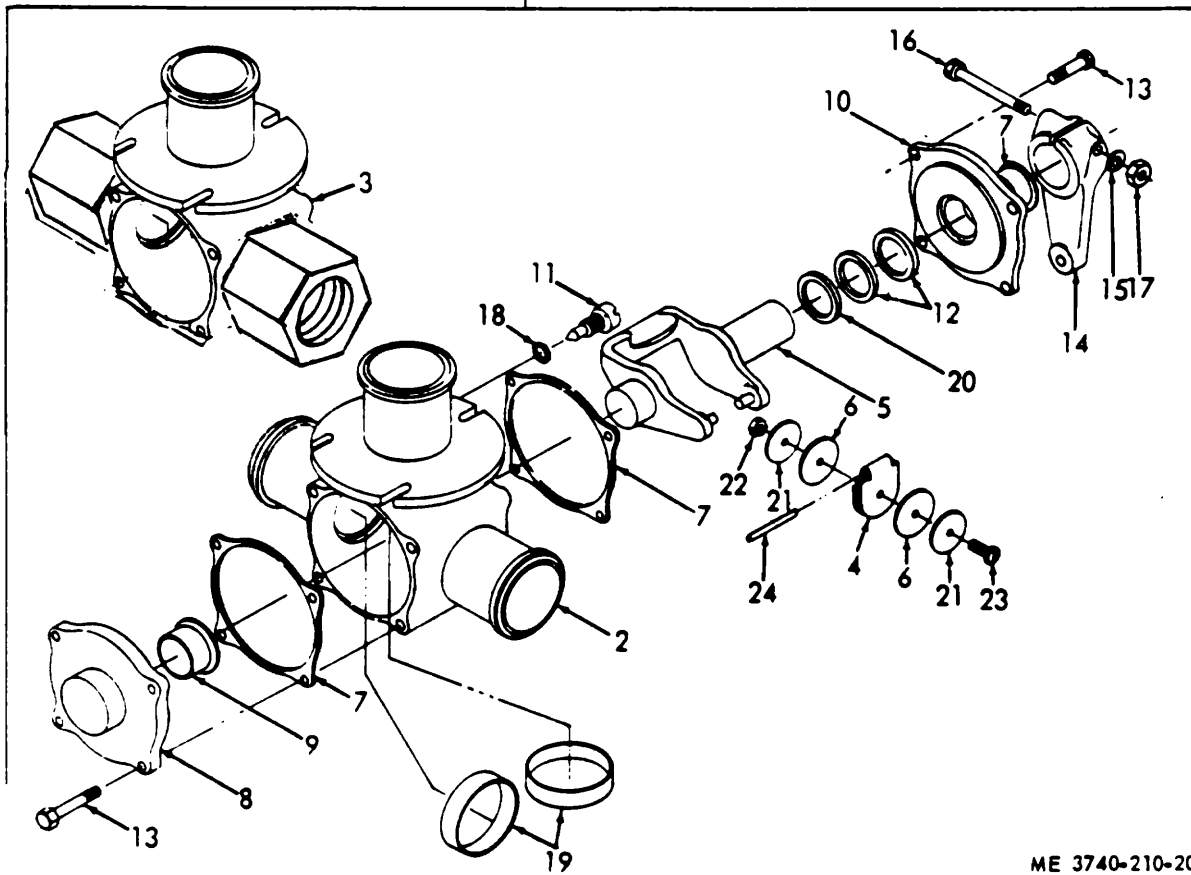
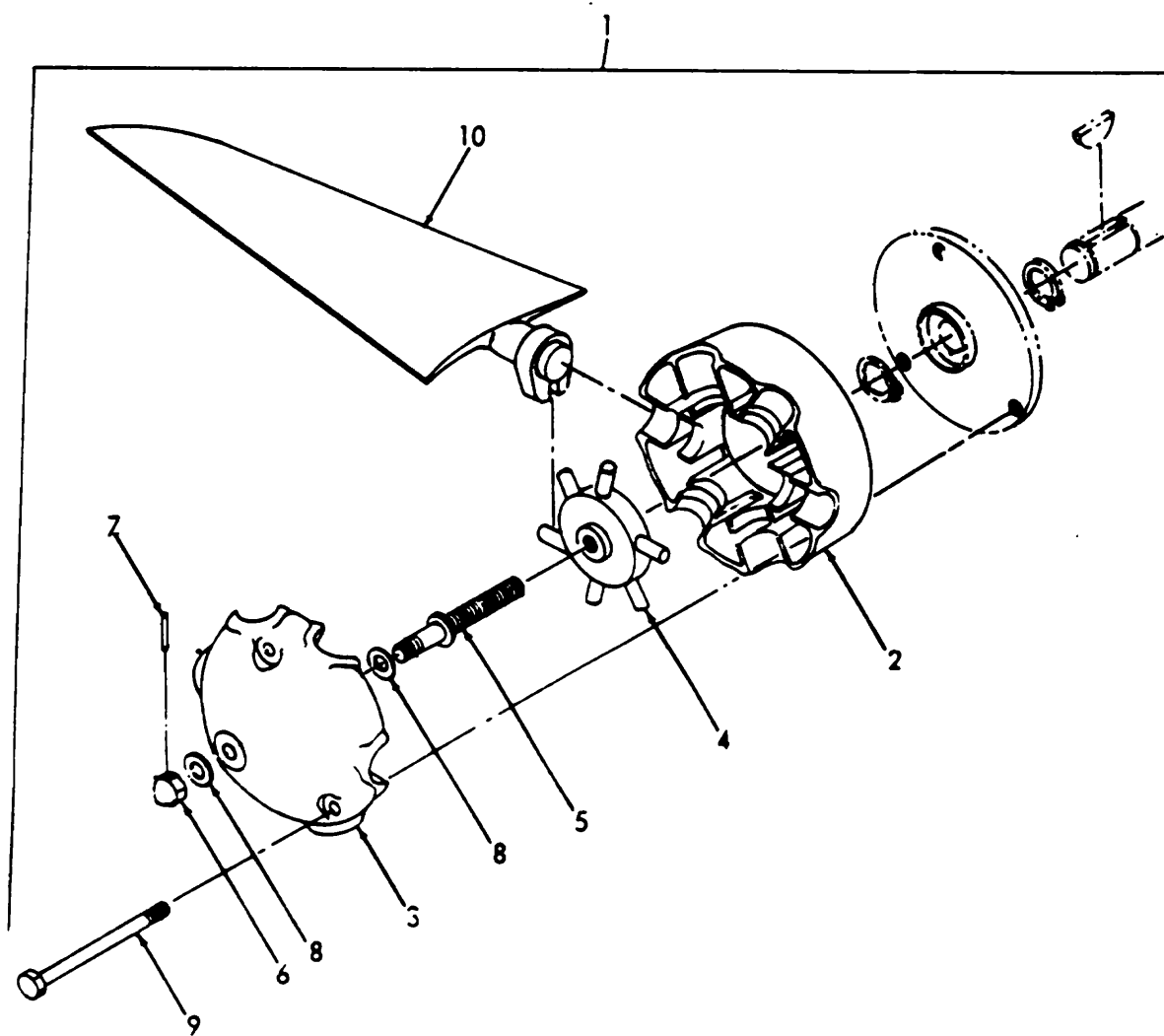

Figure No. 10 Manual Control System



ME 3740-210-20P/11

Figure No. 11 Valve



ME 3740-210-20P/12

Figure No. 12 Windmill

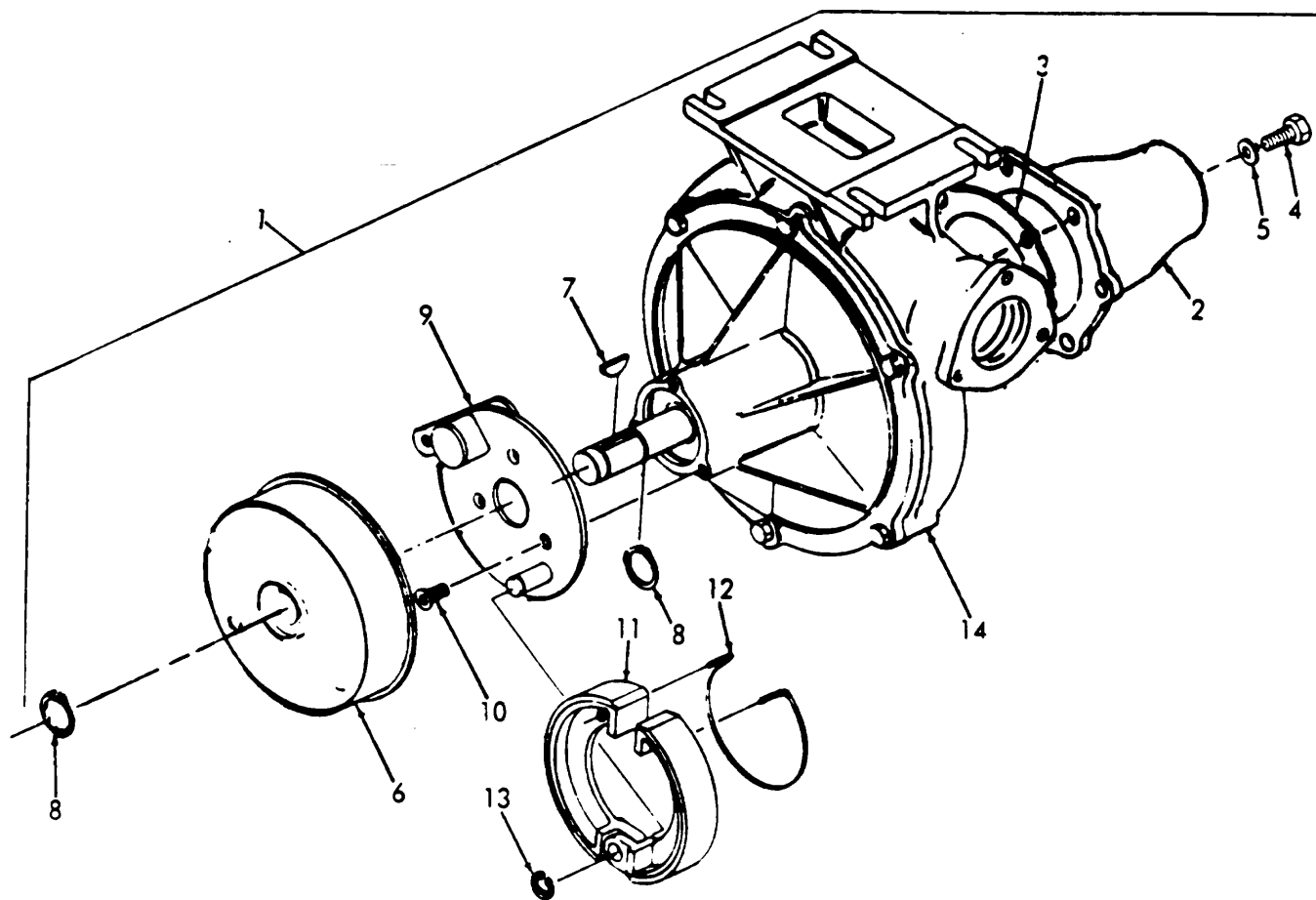

ME 3740-210-20P/13

Figure No. 13 Pump And Brake

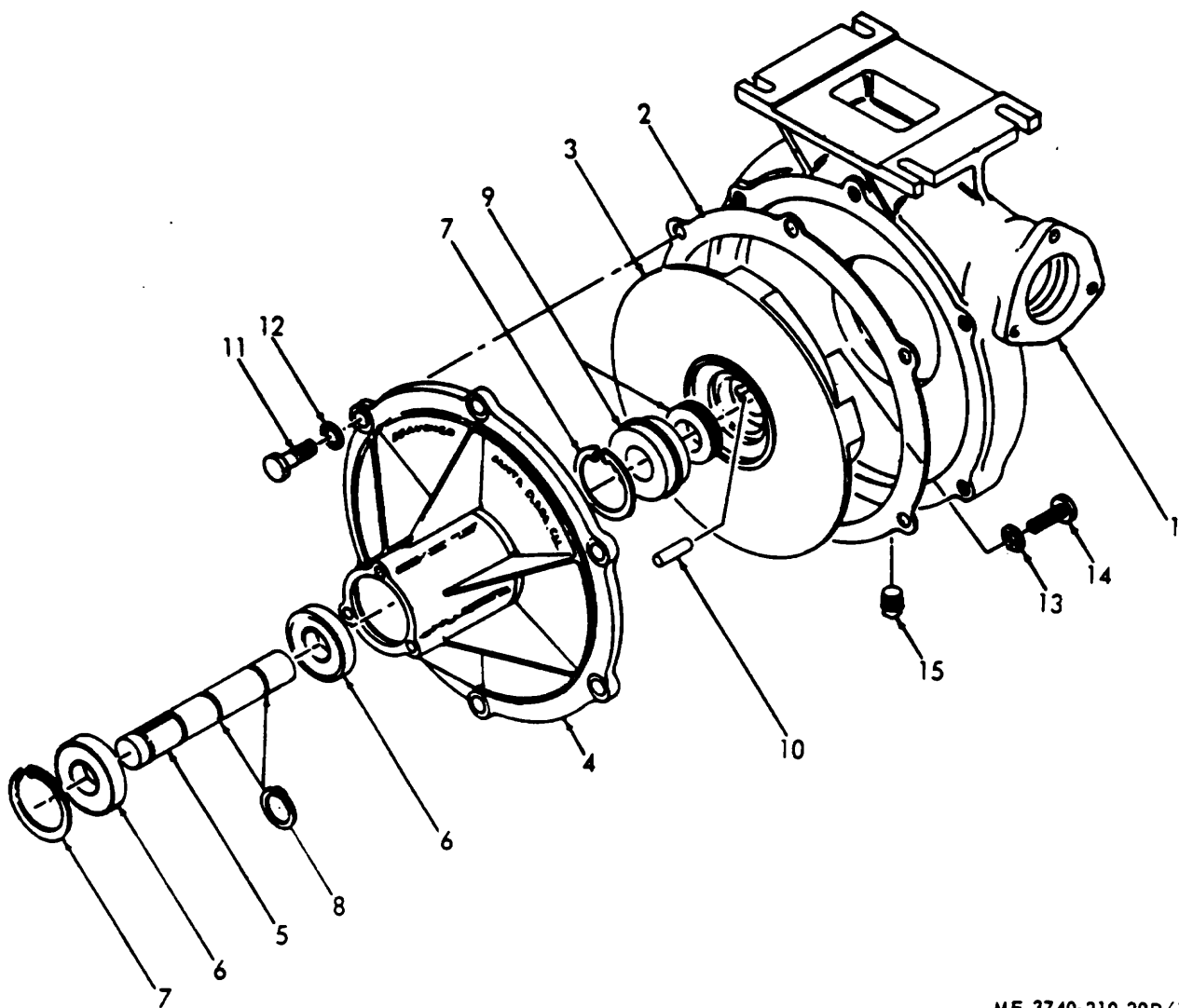

ME 3740-210-20P/14

Figure No. 14 Pump

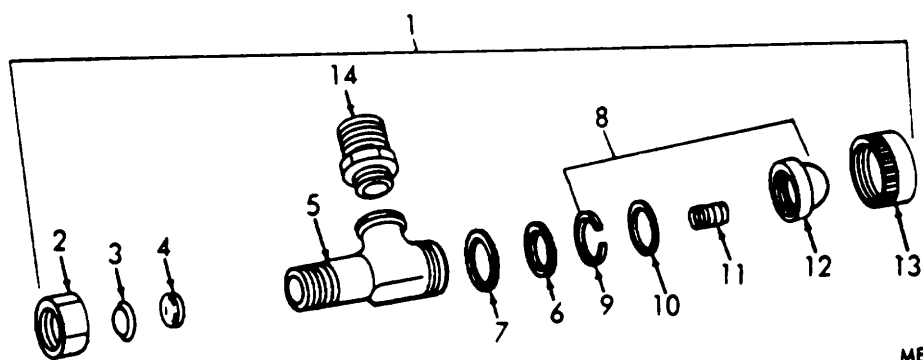

ME 3740-210-20P/15

Figure No. 15 Nozzle

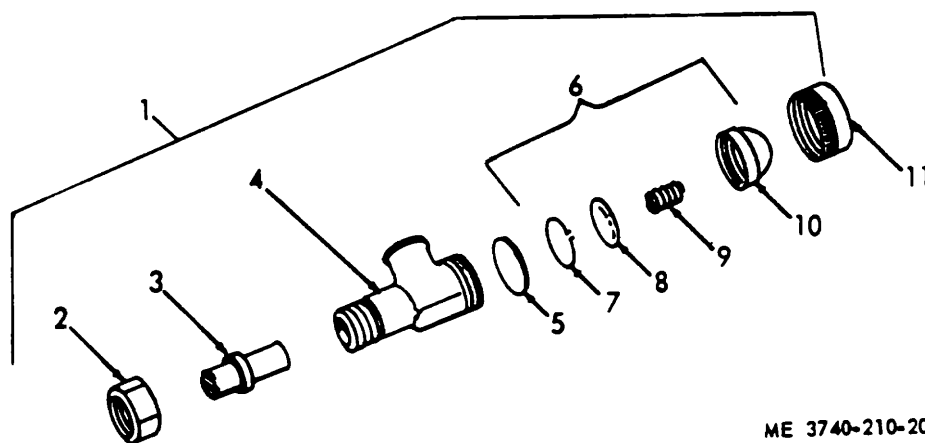

ME 3740-210-20P/16

Figure No. 16 Nozzle

**Section V INDEX-FEDERAL STOCK NUMBER AND REFERENCE NUMBER
CROSS-REFERENCE TO FIGURE AND ITEM NUMBER**

<u>STOCK NUMBER</u>	<u>FIGURE NO.</u>	<u>ITEM NO</u>	<u>STOCK NUMBER</u>	<u>FIGURE NO.</u>	<u>ITEM NO.</u>
1670-179-6250	7	26	4320-168-2098	2	19
1670-179-6251	6	2	4720-143-9262	8	39
1670-179-6252	6	3	4720-143-9264	9	43
2805-981-8749	2	6	4720-168-2091	8	36
2910-177-7766	4	18	4720-541-9266	8	34
2910-177-7767	4	8	4730-168-2083	1	4
2910-177-7768	5	3		1	REF
2910-177-7769	3	27	4730-168-2084	1	3
2920-177-7770	3	28	4730-168-2086	6	7
2920-177-7771	4	42	4730-168-2087	6	6
2920-977-1118	3	43	4730-168-2088	1	11
2920-979-6475	3	33	4730-168-2089	1	2
2940-982-9397	5	9	4730-168-2090	1	9
2090-177-7772	3	13	4730-186-7798	6	5
2990-177-7773	3	23	4730-186-9493	8	38
2990-977-1004	3	10	4730-196-9585	10	23
2990-978-7302	3	9	4730-278-2682	10	22
3130-179-7258	2	8	4730-278-3678	9	34
3130-179-7259	14	6	4730-278-4231	1	8
3740-179-6675	13	9	4730-287-0263	9	32
3740-179-6676	13	11	4730-424-0894	14	15
3740-179-6683	8	45	4820-724-0768	1	10
3740-179-6684	8	46	5305-018-1061	13	4
3740-179-6692	16	1	5305-021-3615	2	24
3740-179-6693	16	6	5305-021-3668	2	34
3740-179-6694	16	11	5305-042-4987	7	7
3740-179-6695	16	3	5305-043-1942	3	17
3740-179-6696	16	3	5305-059-8446	5	22
3740-179-6698	16	3	5305-207-8253	2	35
3740-179-6699	15	6	5305-208-8262	9	4
	16	5	5305-360-7668	4	38
3740-179-6700	15	7		5	12
3740-179-6701	9	18	5305-510-1476	3	4
3740-179-6703	8	6	5305-551-0146	5	14
3740-179-6704	12	1	5305-558-3858	5	35
3740-179-6705	12	2	5305-682-6023	2	4
3740-179-6706	12	3		5	16
3740-179-6707	12	4	5305-805-9748	5	32
3740-179-6708	12	5	5305-818-7814	2	14
3740-179-6709	12	10	5305-872-8260	14	11
3740-179-6710	13	1	5306-150-9907	6	27
3740-179-6711	13	3	5306-151-0784	6	9
3740-179-6712	13	6		9	17
3740-179-6713	13	14	5306-151-0785	8	17
3740-179-6714	14	1	5306-151-1282	10	12
3740-179-6715	14	2	5306-151-1406	8	25
3740-179-6716	14	3		9	25
3740-179-6717	14	4	5306-151-1424	9	36
3740-179-6719	14	5	5306-151-1426	9	44
3740-179-6720	11	1		10	6
3740-179-6722	1	5	5306-156-2287	6	12
	1	REF	5306-156-2338	14	14
3740-179-6723	6	4	5306-156-2695	8	50
3740-179-6724	9	23	5306-180-0014	8	9
3740-179-6725	9	28	5306-180-1483	9	9
3740-179-6726	6	21	5306-182-2057	8	41
3740-179-6727	6	8	5306-209-2648	9	12
3740-179-6728	6	16	5306-266-4102	11	13
3740-179-6729	6	17	5306-271-6864	9	19
3740-179-6730	6	22	5306-274-2119	6	32
3740-179-6732	6	24		8	32
3740-179-6733	6	31		9	8
3740-179-6734	6	29	5306-337-2861	6	20
3740-179-6735	6	26	5306-656-0358	6	28
3740-179-6736	8			8	17
3740-179-6737	8	3	5306-722-0393	9	41
3740-179-6738	8	4	5306-725-1908	9	22
3740-179-6739	8	7	5306-795-3280	12	9
3740-179-6740	9	16	5310-050-3345	10	14
3740-179-6741	11	1	5310-059-9908	3	21
3740-179-6679	8	8		4	10
3740-179-6680	10	1	5310-061-7325	6	33
3740-179-6681	10	2		9	REF
3740-179-6682	10	15		8	27
3740-179-6686	10	16		9	15
3740-179-6687	10	16	5310-141-1795	6	13
3740-179-6688	10	17		8	26
3740-179-6690	10	18		9	REF
4320-168-2093	2	17		9	20
4320-168-2094	2	12		10	7
4320-168-2095	2	11		13	5
4320-168-2096	2	27	5310-167-0766	9	14
4320-168-2097	1	16	5310-167-0818	6	10

**Section V INDEX-FEDERAL STOCK NUMBER AND REFERENCE NUMBER
CROSS-REFERENCE TO FIGURE AND ITEM NUMBER**

<u>STOCK NUMBER</u>	<u>FIGURE NO.</u>	<u>ITEM NO.</u>	<u>STOCK NUMBER</u>	<u>FIGURE NO.</u>	<u>ITEM NO.</u>
5310-167-0818	6	REF			
	8	14			
	8	REF			
	9	5			
	9	REF			
	11	15			
5310-167-0820	10	13			
	14	12			
5310-167-0821	9	10			
5310-167-0834	8	48			
5310-167-0837	12	8			
5310-176-0825	10	21			
5310-176-8108	8	49			
5310-531-9515	14	13			
5310-543-2740	2	23			
5310-543-4431	3	19			
5310-579-0848	6	15			
	9	39			
5310-595-7475	6	14			
5310-625-5756	3	20			
5310-655-6932	4	40			
5310-660-2648	3	18			
5310-783-8778	5	33			
5310-797-3615	12	6			
5310-797-4065	2	13			
5310-815-9849	2	37			
5310-828-8189	7	13			
5310-933-8121	2	36			
	4	39			
5310-966-4117	4	11			
5315-017-9252	8	51			
5315-616-5521	13	7			
5315-839-5820	8	53			
5330-054-6865	1	15			
5330-179-6243	2	18			
5330-179-6244	2	25			
5330-179-6246	8	40			
5330-179-6247	2	28			
5330-179-6248	14	9			
5330-179-6249	2	16			
5330-852-5034	2	9			
5335-178-1363	1	14			
5340-143-0335	13	8			
	14	8			
5340-178-1365	2	32			
5340-178-1366	2	15			
5340-178-1367	2	15			
5340-178-1368	3	12			
5340-178-1369	13	12			
5340-178-3388	8	31			
5340-186-3408	9	1			
5340-622-1799	13	13			
5340-804-9746	14	7			
5340-937-5358	3	25			
6545-914-3480	7	24			
6685-883-1808	10	19			
9505-293-4208	8	42			

**Section V INDEX-FEDERAL STOCK NUMBER AND REFERENCE NUMBER
CROSS-REFERENCE TO FIGURE AND ITEM NUMBER**

REFERENCE NO.	MFG. CODE	FIGURE NO.	ITEM NO.	REFERENCE NO.	MFG. CODE	FIGURE NO.	ITEM NO.
ADCH24	22065	9	31	A59031	29201	3	1
AN23-11A	88044	6	27	A59285	29201	5	31
AN24-11	88044	8	50	A59299	29201	5	15
AN24-18A	88044	6	12	A59301A	29201	5	21
AN3-10A	88044	6	9	A59535B	29201	5	3
"	88044	9	17	A59547	29201	2	7
AN3-13A	88044	11	16	A59607	29201	5	17
AN3-22A	88044	6	20	A62935	29201	5	30
AN3-30A	88044	9	22	A63271	29201	4	1
AN3-4A	88044	9	41	A63477	29201	4	30
AN3-5A	88044	6	32	A63496	29201	4	33
	88044	8	32	A64140-1	29201	4	8
	88044	9	8	A64446	29201	3	13
AN3-6A	88044	6	28	A64516	22901	3	6
	88044	8	17	D10	82247	15	3
AN3-7A	88044	8	13	D6	82247	15	3
AN316-6	88044	6	15	D8	82247	15	3
	88044	9	39	FIG45-150 -X30	72100	10	19
AN320-4	88044	8	49	GS24SS	22065	8	30
AM363C1032	88044	11	22	GS28SS	22065	8	44
AN365-1032	88044	11	17	GS32SS	22065	8	37
AN38H4A	88044	8	41		22065	9	27
AN380-2-4	88044	8	51	H24-56v	78357	1	2
AN4C6A	88044	14	14	LP3-22A	02615	12	9
AN4-10A	88044	9	36	MD46-16	73134	6	16
AN4-11	88044	8	52	MS20364-428	96906	6	14
AN4-32A	88044	8	25	MS365-1032	96906	6	1
	88044	9	25		96906	6	REF
AN4-6	88044	9	44	MS20365-1032C	96906	6	25
	88044	10	6		96906	8	33
AN43B-10A	88044	9	12		96906	9	6
AN43B-4A	88044	9	19	MS20365-428	96906	9	45
AN5-15A	88044	10	12		96906	10	8
AN50910R10	88044	9	4	MS20365-428C	96906	6	33
AN525-10R12	88044	8	9		96906	8	27
AN25010R12	88044	11	23		96906	9	15
AN530-10-10	88044	7	12		96906	9	REF
AN6-11A	88044	9	9	MS20365-524	96906	10	14
AN6230-7	88044	1	15	MS20365 624	96906	7	9
AN742-D24	88044	9		MS20365-624C	96906	9	11
AN742-D28	88044	8	31	MS20392-2-17	96906	8	47
AN816-20D	88044	8	38	MS20995C32	96906	8	42
AN816-54D	88044	10	23	MS21919-8	96906	9	38
AN822-50	88044	9	34	MS28741-20-0122	96906	8	39
AN823-20D	88044	8	35	MS28741-20-0520	96906	8	34
AN823-21D	88044	9	32	MS28741-5-0720	96906	9	43
AN842-24D	88044	8	29	MS35425-41	96906	7	13
AN910-2D	88044	10	22	MS35756-13	96906	13	7
AN911-2	81350	6	5	MS9048-008	96906	12	7
AN936-10	88044	9	42	M31CR420-10E	22065	10	4
AN960C416	88044	14	13	NAS1211B15	22065	9	37
AN960-10	88044	6	REF	NAS75-4-010	22065	9	13
	88044	6	10	N5000-156	79136	14	7
	88044	8	14	SS6	22065	9	40
	88044	8	REF	WB661-1-25N	95957	6	3
	88044	9	5	WB661-1-52N	95957	6	2
	88044	9	REF	W3325	82247	15	14
	88044	11	15	XLS1-12X3	29201	1	16
AN960-101	88044	8	48	1124211T	98991	1	10
AN960-1016	88044	10	21	1325AL	82247	15	2
AN960-416	88044	6	13		82247	16	2
	88044	8	26	1-4PT	17224	6	6
	88044	9	20	1-4X20X1-2	02615	13	10
	88044	9	REF	2068	22065	10	20
	88044	10	7	25038	29201	4	43
	88044	13	5	2510	82247	16	3
AN960 516	88044	10	13	2530	82247	16	3
	88044	14	12	2560	82247	16	3
AN960-616	88044	9	10	2646	22065	8	2
AN960-616L	88044	12	8	2646-1	22065	8	3
AN970-4	88044	9	14	2646-3	22065	8	4
AVHC24-24FAMPH24V	78357	1	3	2770-3	22065	7	26
AVHC24-24MAMPH24V	78357	1	9	28008	29201	3	35
AVHN24-24F	22065	9	30	28028	29201	3	34
AVHN24-24FADCH24	78537	1	4	3-8-16	22065	7	23
	78537	1	REF	3003	22065	9	2
A57650-3	29201	3	2	3010	22065	8	1
A58799D	29201	4	21	3020	22065	8	23
A58818A	29201	5	13	3025	22065	8	18
A58826	29201	5	5	30261	29201	3	30
A5882	29201	5	7	3027-1	22065	8	20
A58903B	29201	4	34	3027-3	22065	8	19
A58914	29201	3	33	3028	22065	6	8
A58934	29201	3	32	3029	22065	6	22

**Section V INDEX-FEDERAL STOCK NUMBER AND REFERENCE NUMBER
CROSS-REFERENCE TO FIGURE AND ITEM NUMBER**

<u>REFERENCE NO.</u>	<u>MFG. CODE</u>	<u>FIGURE NO.</u>	<u>ITEM NO.</u>	<u>REFERENCE NO.</u>	<u>MFG. CODE</u>	<u>FIGURE NO.</u>	<u>ITEM NO.</u>
3029-1	22065	6	24	4821SS	82247	16	7
3029-40	22065	6	23	5133-37	79136	13	13
3030	22065	9	7	5160-66	22065	13	8
3031	22065	6	17		22065	14	8
3031-1	22065	6	18	5-40	22065	7	16
3031-3	22065	6	19	5-40X3-7-8	22065	7	15
3032	22065	6	21	54182	29201	2	25
3033	22065	8	10	54183	29201	2	18
3034	22065	6	30	54185-1	29201	2	30
3038	22065	9	26	54408	29201	3	43
3039-1	22065	9	16	54576s	29201	4	42
3039-3	22065	9	18	54861	29201	2	32
3042-1	22065	8	12	54862	29201	2	33
3043	22065	8	11	54867-1	29201	2	31
3044-1	22065	8	15	55871	29201	4	24
3045	22065	8	16	56	82247	15	4
3046	22065	8	24	56607	29201	4	3
3047	22065	9	21	568-011	22065	11	18
3048	22065	9	35	57289-1	29201	5	20
3049	22065	8	46	58319A	29201	5	8
3051	22065	9	29	58362	29201	5	19
3055-1	22065	9	24	58392-1	29201	5	10
3055-3	22065	9	28	58513	29201	4	20
3059	22065	8	5	58519	29201	4	16
3060	22065	6	1	58537A	29201	5	1
3062	22065	8	6	58619-2	29201	2	29
3063	22065	8	6	58661-2	29201	2	12
	22065	8	28	58688A	29201	2	9
3064	22065	8	8		29201	4	22
3068	22065	8	7	58706-4	29201	4	44
3069-11	22065	6	4	58718-2	29201	2	17
3070	22065	9	33	58724	29201	4	31
3074	22065	8	21	58725	29201	4	26
3076	22065	8	22	58726	29201	4	27
3077	22065	9	23	58732	29201	4	6
3082-1	22065	8	54	58756	29201	3	23
3082-3	22065	8	43	58757B	29201	3	22
3083-1	22065	1	1	58758	29201	3	25
3083-11	22065	1	8	58763	29201	3	16
3083-13	22065	1	7	58764A	29201	3	12
3083-3	22065	1	6	58765	29201	3	26
308-5	22065	1	5	58773-5	29201	5	6
	22065	1	REF	58775	29201	5	25
3085-1	22065	6	31	58186	29201	5	27
3085-3	22065	6	29	58780	29201	5	2
3085-7	22065	6	26	58806	29201	3	9
3087-1	22065	9	3	58809	29201	3	27
3091	22065	10	1	58810	29201	3	37
3091-17	22065	10	17	58811	29201	3	31
3091-19	22065	10	18	58847	29201	3	11
3091-21	22065	10	9	58851	29201	3	24
3091-40	22065	10	2	58862	29201	4	15
3091-5	22065	10	16	58865	29201	4	14
3091-50	22065	10	3	58866	29201	4	13
3091-7	22065	10	16	58867	29201	4	12
3095	22065	7	1	58872	29201	3	44
3095-1	22065	7	3	58874	29201	3	42
3095-19	22065	7	4	58875A	29201	3	39
3095-21	22065	7	19	58877	29201	4	37
3095-23	22065	7	20	58915	29201	3	10
3095-35	22065	7	17	58956	29201	2	8
3095-37	22065	7	18		29201	4	23
3095-41	22065	7	10	58963	29201	2	1
3095-43	22065	7	25		29201	3	5
3095-67	22065	7	6	59053	29201	5	26
3095-69	22065	7	8	59058	29201	5	24
3095-73	22065	7	2	59195-2	29201	2	5
3095-81	22065	7	14	59196-2	29201	2	2
3095-83	22065	7	11	59242	29201	5	28
3711	22065	11	9	59260	29201	5	23
4163-30	22065	1	14	59313	29201	3	8
4164P30	22065	1	11	59329	29201	5	18
4165P	22065	1	12	59367	29201	5	29
4166	22065	1	13	59457	29201	4	4
45	82247	15	4	59538	29201	3	40
4618ASB	82247	15	5	59548-2	29201	4	41
4620VI	82247	15	6	59549-1	29201	2	21
	82247	16	5	59550-1	29201	2	20
4622SS	82247	16	9	59594A	29201	2	27
4623ALEF	82247	15	12	59571	29201	4	5
4624AL	82247	15	13	59622	29201	3	29
4632SS	82247	15	11	59642	29201	4	191
4664AL3F	82247	15	1	59644-1	29201	4	18
4821SS	82247	15	9	59760	29201	3	41

**Section V INDEX-FEDERAL STOCK NUMBER AND REFERENCE NUMBER
CROSS-REFERENCE TO FIGURE AND ITEM NUMBER**

<u>REFERENCE NO.</u>	<u>MFG. CODE</u>	<u>FIGURE NO.</u>	<u>ITEM NO.</u>	<u>REFERENCE NO.</u>	<u>MFG. CODE</u>	<u>FIGURE NO.</u>	<u>ITEM NO.</u>
59910	29201	2	28	80882	29201	2	26
6008	22065	10	11	80889	29201	4	32
6008-3	22065	10	10	80891	29201	2	4
6009-5	22065	10	15		29201	5	16
6011	22065	8	45	80893	29201	5	32
6227	82247	15	7	80899	29201	2	10
62691-1	29201	2	22	80916	29201	2	14
62692	29201	2	11	81010-1	29201	2	40
62693-2	29201	2	19	81053	29201	2	37
62695	29201	2	15	81065-2	29201	4	40
62696	29201	2	15	81109-2	29201	3	21
62717	29201	2	13		29201	4	10
63NE066	22065	7	5	81117	29201	3	18
6300T-5	22065	13	14	8296ASB1-4	82247	16	4
6301	22065	14	4	83002	29201	3	19
6302	22065	14	3	83009	29201	2	36
6303-5	22065	14	1		29201	29201	39
6305	22065	14	5	83046	29201	2	39
6306	22065	14	2		29201	5	11
6308T	99189	14	9	83077-1	29201	2	23
6313	22065	13	2	8355	82247	16	1
63250	29201	3	28	84003-1	29201	4	11
6330-3	22065	13	1	84003-4NPT	82247	6	7
63355	29201	2	6	84025	29201	5	33
63407	29201	4	7	84056	29201	3	20
63497-1	29201	4	29	8476AL	82247	16	11
63589	29201	5	9	8522NYL	82247	16	10
63621	29201	4	25	8526NYL	82247	15	10
63726	29201	3	45		82247	16	8
64049A	29201	3	15	86324	29201	5	4
6440	29201	3	14	9758ASB	82247	15	8
64443	29201	9	7	9758NYL	82247	16	6
64813	29201	4	36				
65358	29201	4	9				
6609	22065	14	10				
6612	22065	13	3				
6645	22065	12	1				
6647	22062	12	2				
6648	22065	12	3				
6649	22065	12	10				
6652	22065	12	4				
6653	22065	12	5				
6654-2	22065	13	9				
6654-3	22065	13	11				
66544	22065	13	12				
6655	22065	13	6				
6672	22065	12	6				
7208	22065	11	14				
7210	22065	11	12				
7307	22065	11	7				
7310	22065	11	20				
7313	22065	11	11				
7400	22065	11	1				
7400-1	22065	11	1				
7401-1	22065	11	3				
7401	2206	11	2				
7402	22065	11	8				
7403	22065	11	10				
7404	22065	11	5				
7406	22065	11	4				
7407	22065	8	40				
7409	22065	11	6				
7416	22065	11	21				
7417 1	22065	11	24				
7419	22065	11	19				
7578	22065	11	28				
75120	29201	4	35				
75892	29201	5	34				
76413	29201	3	38				
76421	29201	3	36				
79NE040	22065	7	22				
80042	29201	2	38				
80259	29201	2	34				
80271	29201	2	35				
80355	29201	2	24				
80481	29201	5	12				
80513	29201	4	17				
80575	29201	5	14				
80577	29201	5	35				
80648	29201	3	17				
80658	29201	5	22				
80676	29201	3	4				
80821	29201	2	3				
80867	29201	4	38				

<u>ITEM NOT ILLUSTRATED</u>			
<u>STOCK NUMBER</u>	<u>GROUP NO.</u>	<u>PAGE NO.</u>	
3740-179-6741	02	20	
3740-179-6736	02	11	
4820-168-2065	01	08	

<u>REFERENCE NO.</u>	<u>MFG. CODE</u>	<u>GROUP NO.</u>	<u>PAGE NO.</u>
K4211T	98991	01	08
K7400	22065	02	20
3048-1	22065	02	14
3048-3	22065	02	15
3062	22065	02	11
3080	22065	01	01
58971	29201	01	08
58972	29201	01	08
59222	29201	01	07
59787	29201	01	07
86301	29201	01	08

By Order of the Secretary of the Army:

Official:

KENNETH G. WICKHAM,
Major General, United States Army.
The Adjutant General.

W. C. WESTMORELAND,
General, United States Army,
Chief of Staff.

Distribution:

To be distributed in accordance with DA Form 12-25, Section I, (qty rqr block No. 150) organizational maintenance requirements for Mobility Support Equipment: Pest Control.

RECOMMENDED CHANGES TO EQUIPMENT TECHNICAL PUBLICATIONS



*THEN...JOT DOWN THE
DOPE ABOUT IT ON THIS FORM.
CAREFULLY TEAR IT OUT, FOLD IT
AND DROP IT IN THE MAIL.*

SOMETHING WRONG WITH PUBLICATION

FROM: (PRINT YOUR UNIT'S COMPLETE ADDRESS)

DATE SENT

PUBLICATION NUMBER	PUBLICATION DATE	PUBLICATION TITLE
--------------------	------------------	-------------------

BE EXACT PIN-POINT WHERE IT IS				IN THIS SPACE, TELL WHAT IS WRONG AND WHAT SHOULD BE DONE ABOUT IT.
PAGE NO.	PARA-GRAPH	FIGURE NO.	TABLE NO.	

PRINTED NAME, GRADE OR TITLE AND TELEPHONE NUMBER	SIGN HERE
---	-----------

The Metric System and Equivalents

Linear Measure

1 centimeter = 10 millimeters = .39 inch
 1 decimeter = 10 centimeters = 3.94 inches
 1 meter = 10 decimeters = 39.37 inches
 1 dekameter = 10 meters = 32.8 feet
 1 hectometer = 10 dekameters = 328.08 feet
 1 kilometer = 10 hectometers = 3,280.8 feet

Weights

1 centigram = 10 milligrams = .15 grain
 1 decigram = 10 centigrams = 1.54 grains
 1 gram = 10 decigrams = .035 ounce
 1 decagram = 10 grams = .35 ounce
 1 hectogram = 10 decagrams = 3.52 ounces
 1 kilogram = 10 hectograms = 2.2 pounds
 1 quintal = 100 kilograms = 220.46 pounds
 1 metric ton = 10 quintals = 1.1 short tons

Liquid Measure

1 centiliter = 10 milliliters = .34 fl. ounce
 1 deciliter = 10 centiliters = 3.38 fl. ounces
 1 liter = 10 deciliters = 33.81 fl. ounces
 1 dekaliter = 10 liters = 2.64 gallons
 1 hectoliter = 10 dekaliters = 26.42 gallons
 1 kiloliter = 10 hectoliters = 264.18 gallons

Square Measure

1 sq. centimeter = 100 sq. millimeters = .155 sq. inch
 1 sq. decimeter = 100 sq. centimeters = 15.5 sq. inches
 1 sq. meter (centare) = 100 sq. decimeters = 10.76 sq. feet
 1 sq. dekameter (are) = 100 sq. meters = 1,076.4 sq. feet
 1 sq. hectometer (hectare) = 100 sq. dekameters = 2.47 acres
 1 sq. kilometer = 100 sq. hectometers = .386 sq. mile

Cubic Measure

1 cu. centimeter = 1000 cu. millimeters = .06 cu. inch
 1 cu. decimeter = 1000 cu. centimeters = 61.02 cu. inches
 1 cu. meter = 1000 cu. decimeters = 35.31 cu. feet

Approximate Conversion Factors

<i>To change</i>	<i>To</i>	<i>Multiply by</i>	<i>To change</i>	<i>To</i>	<i>Multiply by</i>
inches	centimeters	2.540	ounce-inches	Newton-meters	.007062
feet	meters	.305	centimeters	inches	.394
yards	meters	.914	meters	feet	3.280
miles	kilometers	1.609	meters	yards	1.094
square inches	square centimeters	6.451	kilometers	miles	.621
square feet	square meters	.093	square centimeters	square inches	.155
square yards	square meters	.836	square meters	square feet	10.764
square miles	square kilometers	2.590	square meters	square yards	1.196
acres	square hectometers	.405	square kilometers	square miles	.386
cubic feet	cubic meters	.028	square hectometers	acres	2.471
cubic yards	cubic meters	.765	cubic meters	cubic feet	35.315
fluid ounces	milliliters	29.573	cubic meters	cubic yards	1.308
pints	liters	.473	milliliters	fluid ounces	.034
quarts	liters	.946	liters	pints	2.113
gallons	liters	3.785	liters	quarts	1.057
ounces	grams	28.349	liters	gallons	.264
pounds	kilograms	.454	grams	ounces	.035
short tons	metric tons	.907	kilograms	pounds	2.205
pound-feet	Newton-meters	1.356	metric tons	short tons	1.102
pound-inches	Newton-meters	.11296			

Temperature (Exact)

°F	Fahrenheit temperature	5/9 (after subtracting 32)	Celsius temperature	°C
----	---------------------------	-------------------------------	------------------------	----

PIN: 005451-001